

Sequence of Operation

Upon entering the room the occupant inserts the key card into the key card switch, this will send an occupied signal to the controllers in the room. The ERM-FLU will close its relay enabling power to flow to the lights in the room. The ERM-FPU will close (or open) its relay enabling the HVAC system to function normally. The ELEDR will close the relay allowing power to flow to the controlled receptacle/s. When the occupant removes the key card upon leaving the room the key card switch will send an unoccupied signal to the controllers in the room and all the devices will go to their unoccupied state. For the lighting this will stop the flow of power (after a predetermined amount of time) to the lights and the HVAC will go into setback mode or turn off, depending on the mechanical equipment. If needed, an RTS temperature sensor may be added to the space for setback control of the HVAC system. For added energy efficiency, a window switch may be used to put the HVAC system into setback mode as well when the window is opened.

*For hotels/motels that don't use key cards for room access, a door switch and occupancy sensor combination may be used. Each time the door is opened and closed and the sensor sees motion, the room will lock into occupied state. Each time the door is open and closed, the sensor will communicate to the controllers if the space is occupied or not. If no motion is sensed after 15 minutes (adjustable) of the door closing the room will go into the unoccupied mode.

Typical Material List		
Qty	Part #	Description
1	ELEDR-xU	Power Load Controller 120-277V 20A
1	ERM-FLU	Power Load Controller 120V 15A
1	ERM-FPU-24	PTAC Controller Single channel 24V AC/DC
1	PTM265KCA	Key Card Switch

SPECIFICATION:

1. LIGHTING CONTROL SYSTEM TO BE MANUFACTURED BY ECHOFLEX SOLUTIONS INC.

2. ECHOFLEX LIGHTING CONTROL SYSTEM SHALL HAVE THE ABILITY TO BE FACTORY PRE-LINKED AND PRE-CONFIGURED OR PROGRAMMED ON SITE USING SIMPLE TAP, SMART CLICK OR GARIBALDI SOFTWARE.

3. CONTROLLERS SHALL BE ABLE TO FUNCTION AS A STAND ALONE SYSTEM ALONG WITH THEIR OPTIONAL PERIPHERAL WIRELESS DEVICES INCLUDING A WALL SWITCH, SPLIT CONTROLLED RECEPTACLE, AND OCCUPANCY SENSOR.

4. CONTROLLERS SHALL BE ABLE TO BE NETWORKED TOGETHER TO FORM AN INTEGRATED BUILDING SOLUTION.

5. ECHOFLEX ELEDR: POWER LOAD CONTROLLER SHALL BE ETL RECOGNIZED AND UL LISTED, CONFORMING TO UL60730, AND CERTIFIED TO CAN/CSA STANDARD E60730 AND UL924. ALL SYSTEM CONTROL ELECTRONICS SHALL STORE PROGRAMMING IN NON-VOLATILE MEMORY. THE CONTROLLER SHALL BE CAPABLE OF REPEATING SIGNALS AND TRANSMITTING STATUS.

6. OCCUPANCY SENSORS (OS): OCCUPANCY SENSOR SHALL BE SOLAR POWERED WIRELESS SENSOR WITH AN OPTIONAL BATTERY. SENSOR SHALL BE COMPATIBLE WITH OCCUPANCY AND VACANCY MODES WHEN USED IN CONJUNCTION WITH THE POWER LOAD CONTROLLER. SENSOR SHALL PROVIDE LED INDICATION FOR RF RANGE CONFIRMATION. SENSOR SHALL WIRELESSLY COMMUNICATE WITH THE SPLIT CONTROLLED RECEPTACLE. SENSOR SHALL HAVE ABILITY TO FUNCTION UP TO 9 DAYS IN COMPLETE DARKNESS.

7. PHOTO SENSORS (PS): PHOTO SENSOR SHALL BE SOLAR POWERED WIRELESS SENSOR WITH AN OPTIONAL BATTERY. SENSOR SHALL BE COMPATIBLE WITH OPEN AND CLOSED LOOP MODES WHEN USED IN CONJUNCTION WITH THE DIMMING CONTROLLER. SENSOR SHALL PROVIDE LED INDICATION FOR RF RANGE. LIGHT SENSOR SHALL BE CAPABLE OF READING LUX LEVELS BETWEEN 0 & 65,500.

8. RF SYSTEM SHALL NETWORK WIRELESSLY. INTEGRATION WITH BMS/DEMAND RESPONSE VIA THE USE OF GATEWAYS AND WIRELESS/WIRED I/O INTERFACES. VERIFY AND INSTALL ONLY THOSE INTERFACES INDICATED ON THE PLANS.

9. EC SHALL INSTALL ECHOFLEX SYSTEM AS INDICATED PER MANUFACTURER'S FINAL DRAWINGS AND INSTALLATION DOCUMENTS IN ACCORDANCE TO ALL LOCAL AND NATIONAL CODES. FACTORY ONSITE START UP AND TRAINING IS OPTIONAL. ECHOFLEX REQUIRES 3 WEEKS ADVANCED NOTICE TO SCHEDULE ONSITE START UP IF REQUESTED. ECHOFLEX WILL PROVIDE SYSTEM VERIFICATION AND ADJUST PROGRAMMING IF REQUIRED TO CUSTOMER REQUIREMENTS.

10. THIS DRAWING REPRESENTS DESIGN CONCEPT AND INTENT ONLY. WE DO NOT GUARANTEE THE INFORMATION IN THIS DOCUMENT IS SUITABLE FOR YOUR PARTICULAR APPLICATION. NOR DO WE ASSUME ANY RESPONSIBILITY FOR YOUR SYSTEM DESIGN, INSTALLATION OR OPERATION. WE RESERVE THE RIGHT TO MAKE CHANGES TO THE PRODUCTS DESCRIBED OR INFORMATION HEREIN AT ANY TIME WITHOUT NOTICE AND WITHOUT ANY OBLIGATION.

11. SPECIFICATIONS SUBJECT TO CHANGE WITHOUT NOTICE.

12. TELEPHONE FACTORY SUPPORT IS AVAILABLE AT NO ADDITIONAL COST TO THE EC OR OWNER.

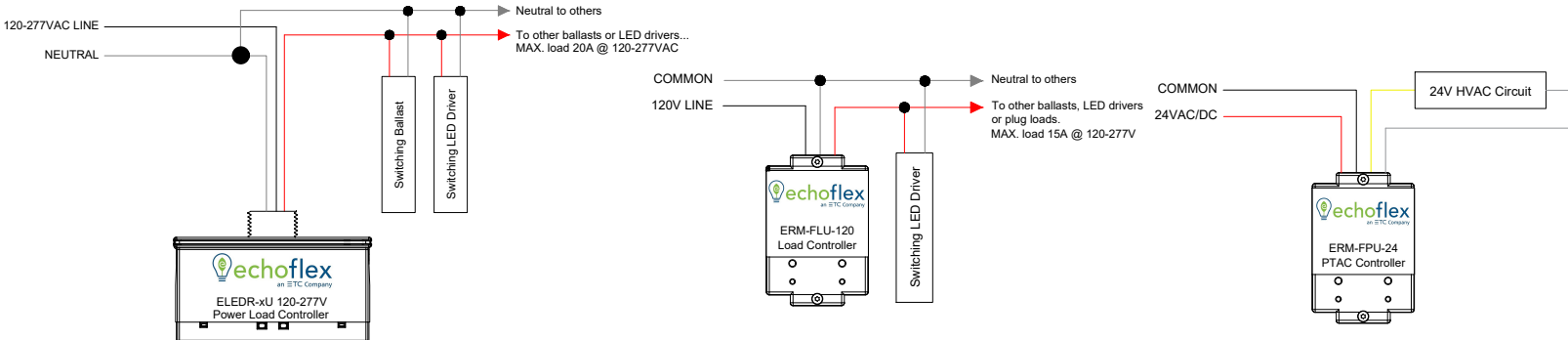

Typical Hotel Room with HVAC Interface

Echoflex Solutions, Inc.

38924 Queens Way Unit #1
Squamish, British Columbia
Canada V8B 0K8
Phone: 1 (778) 733-0111
Toll Free: 1 (888) 324-6359
Fax: 1 (604) 815-0078
echoflexsolutions.com

