

Echoflex Installation Guide

LED Fixture Controller (120–277 VAC) ELED1

Overview

The LED Fixture Controller (120–277 VAC), model ELED1, provides wireless control of an individual fixture or single zone lighting based on occupancy state, manual switch action, ambient light levels, and gateway commands.

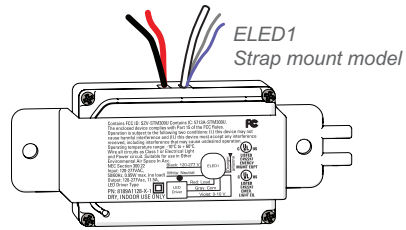
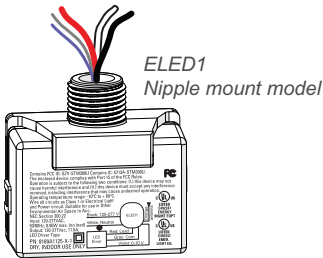

This document covers installation of all ELED1 models. The configuration guide for general lighting applications, models ELED1 and ELED1H, is available for download at echoflexsolutions.com. The configuration guide for the horticultural lighting applications, model ELED1-RHL, is available for download at rayngrowingsystems.com. The product package includes the controller, installation guide, and mounting strap (if applicable).

Prepare for Installation

To ensure optimal function, consider the installation environment and the following guidelines:

- Avoid spaces with high density construction materials and large metal appliances or fixtures as they may disrupt wireless reception.
- For optimal performance, switches and sensors should be installed within a 24 m (80 ft) unobstructed view of the controller.
- Mount the controller to an electrical junction box (preferably non-metallic) or a panel in a location and at a height where it is not subject to tampering by unauthorized personnel.
- Do not install clusters of Echoflex controllers in one location. Rather, distribute them in the lighting zones they control to provide the best wireless reception from linked transmitting devices. Consider adding a repeater to extend the signal, if required.
- Make sure the antenna wire is unrestricted and not in contact with any metal surface.



Corporate Headquarters ■ Middleton, WI, USA | +1 608 831 4116

© 2024 Echoflex Solutions, Inc. | Trademark and patent info: echoflexsolutions.com/ip

Web echoflexsolutions.com | Email info@echoflexsolutions.com | Support service@echoflexsolutions.com

Third-party license agreement info: etconnect.com/licenses | Product information and specifications subject to change. Echoflex intends this document to be provided in its entirety.

8189M2100 Rev F Released 2024-01

Echoflex Installation Guide

LED Fixture Controller (120–277 VAC)

Supplies required to install the controller (not provided):

- Appropriately sized wire nuts
- Wire insulation and small cable ties
- Two 3/8 inch #8 metal screws (for surface mounting strap only)

IMPORTANT SAFEGUARDS

READ AND FOLLOW ALL SAFETY INSTRUCTIONS



WARNING: RISK OF ELECTRIC SHOCK! This device utilizes high voltage and should only be installed by a qualified installer or electrician. Follow all local codes for installation. Before terminating the AC power wiring verify that the main breaker is in the off position and follow the proper lockout/tag out procedures required by NFPA Standard 70E.

AVERTISSEMENT : RISQUE DE DÉCHARGE ÉLECTRIQUE! Cet appareil utilise une haute tension et ne doit être installé que par un installateur qualifié ou un électricien. Suivez tous les codes locaux pour l'installation. Avant de raccorder le câblage du courant alternatif, vérifiez que le disjoncteur principal est en position d'arrêt et suivez les procédures de verrouillage/étiquetage prescrites par la norme NFPA 70E.



WARNING: For indoor use only! Must install to an electrical junction box or wireway.

AVERTISSEMENT : Uniquement pour usage d'intérieur! Doit être installé sur une boîte de raccordement électrique ou un chemin de câbles.

- This product is suitable for use in dry locations where the ambient temperature is -10°C to 60°C (14°F to 140°F).
- Do not use outdoors.
- Do not mount near gas or electric heaters.
- Equipment should be mounted in locations and at heights where it is not subject to tampering by unauthorized personnel.
- The use of accessory equipment not recommended by the manufacturer may cause an unsafe condition.
- Do not use this equipment for other than its intended use.
- Servicing should be performed by qualified service personnel.
- Pollution Degree: 2.

SAVE THESE INSTRUCTIONS

Echoflex Installation Guide

LED Fixture Controller (120–277 VAC)

Installation

Ensure that the junction box is clean and free of obstructions and that all wiring is installed correctly. Review these instructions completely before installing the controller.



Note: *Follow applicable NEC and local electrical code requirements when installing and powering the controller.*

Install Nipple Mount Model

Mount the controller directly to the exterior of the junction box or panel either at the electrical load or before the load in the circuit.

1. Locate the circuit breaker panel and terminate power to the circuit.
2. Remove the cover plate and other hardware from the junction box to access the wiring.
3. Mount the controller.
4. Refer to the [Wiring Diagram on the next page](#) to connect the controller to line power, neutral, and load wires. Use wire nuts on all connections and individually cap any bare wires, except the orange antenna wire.
5. Connect the gray and the violet wires to the driver or ballast's dimming interface (optional).
6. Replace the electrical box cover plate and restore power to the circuit.

Install Strap Mount Model

Mount the controller to the exterior of a lighting fixture or appliance using the supplied mounting strap. The ELED1-RHL is only available with a nipple mount, not strap mount.



Note: *Mounting inside a fixture or other metal cabinet will reduce radio range performance.*

1. Locate the circuit breaker panel and terminate power to the circuit.
2. Slide the mounting strap over the controller housing with the orange antenna wire facing up. Hold the controller in place. The tooled strap prevents the controller from sliding out.
3. Use a power drill to drive a 3/8 inch #8 screw through one of the bracket's mounting holes into the fixture. Repeat for the other mounting hole.
4. Refer to the wiring diagram to connect the controller to line power, neutral, and load wires. Use wire nuts on all connections and individually cap any bare wires, except the orange antenna wire.

Echoflex Installation Guide

LED Fixture Controller (120–277 VAC)

5. Ensure the antenna wire is not close to any metal surface (for example: the lighting fixture metal housing).
6. Connect the gray and the violet wires to the driver or ballast's dimming interface (optional).
7. Restore power to the circuit.



Note: The USB port is for factory use only. Do not attach cables or accessories to this port.

Wiring Diagram

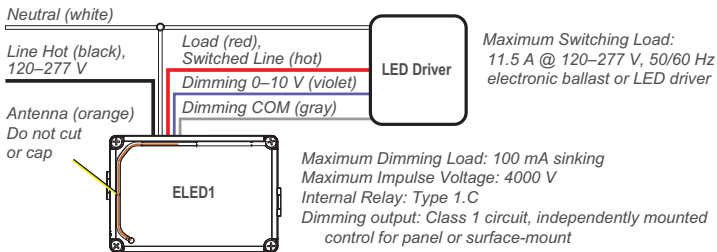

Example UL924 Emergency Fixture



Note: Diagrams for emergency fixtures are for general lighting applications only, not horticulture.

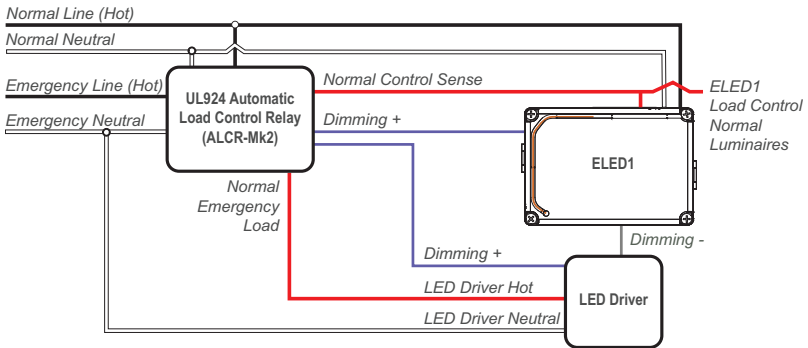

Echoflex Installation Guide

LED Fixture Controller (120–277 VAC)

Example Battery Backup Fixture

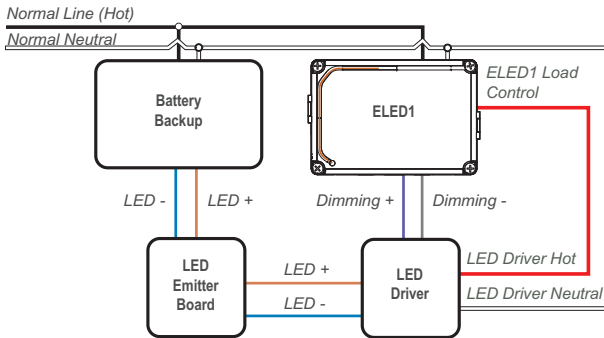

Electrical Terminations

Power to the controller is connected between the Neutral (white) and the Line (black) power (120–277 VAC) conductors. The Class 1 power limited dimming lines (violet and gray wires) can be used to provide 0–10 V intensity control of a dimming ballast or LED driver. The orange wire is an antenna: Do not cut, cap, or connect this wire. Use only UL-approved wire when making connections to the controller.

Connection	Color	Specification
Load	Red	14 AWG, 600 V
Neutral	White	14 AWG, 600 V
Line (hot)	Black	14 AWG, 600 V
Dimming 0–10 V	Violet	18 AWG, 600 V
Dimming COM	Gray	18 AWG, 600 V

User Interface



Note: *Garibaldi Pro software is the ideal tool to manage wireless projects and configurable settings. Garibaldi Pro is available for download at echoflexsolutions.com.*

Two buttons on the controller activate features and set specific configurations directly on the device. Two related status LEDs provide feedback about stored information and activities.

Echoflex Installation Guide

LED Fixture Controller (120–277 VAC)

Learn Button

The **[Learn]** button initiates Link mode for manually linking compatible Echoflex devices to the controller. See the relevant switch or sensor documentation for information on linking. Link mode times out after 60 seconds of inactivity.

Devices can be linked to a controller manually, using Garibaldi Pro, or during the Echoflex pre-commissioning process.

Remote Linking Solution

Use the following method to link the first switch if you cannot access the **[Learn]** button on a controller that has not been pre-commissioned and you do not have Garibaldi Pro software.

This method only works if there are no switches linked to the controller. You cannot link a scene station using this method.

1. Ensure you are within wireless range of the controller and have a wireless paddle switch or a button station.
 - a. If the controller has a linked sensor, you must press the **[Teach]** button on the sensor and complete step 2 within 60 seconds.
2. Click the switch paddle ON three times, OFF three times, and ON three times quickly, for a total of nine consecutive clicks. The relay will toggle and the Power LED will indicate the switch is linked.

Clear Button

Use the **[Clear]** button to reset the controller either to its pre-commissioned state or to its factory default state.

To reset to pre-commissioned state:

1. Press and hold the **[Clear]** button until the red Power and green Learn LEDs start blinking.
2. Release the **[Clear]** button. The Power LED blink codes indicate the type and count of devices linked at pre-commissioning.

To reset to factory default state:

1. Press and hold the **[Clear]** button until the red Power and green Learn LEDs start blinking, and continue to hold for 15 seconds until the LEDs stay on solid.
2. Release the **[Clear]** button. The Power LED displays solid red to indicate factory default state.

Blink Indications

The following tables describe the LED codes that identify linked devices and the LED indications that describe linking activities.

Echoflex Installation Guide

LED Fixture Controller (120–277 VAC)

Device Count Codes

The following codes provide a visible report of the supported devices that are linked to the controller. The Power LED repeats a code of blinks that represent the type and number of linked devices. Long blinks = type. Short blinks = count. If the controller does not have any linked devices, the Power LED remains on solid.

Device Type	Power LED	Learn LED
Switches	1 long blink followed by short blinks that count the switches	Off
Occupancy sensors	2 long blinks followed by short blinks that count the sensors	Off
Photo sensor (maximum of 1)	3 long blinks followed by short blink that counts the sensor	Off
Gateways and TimeClocks	4 long blinks followed by short blinks that count the devices	Off
Demand response	5 long blinks followed by short blinks that count the devices	Off
Entry door sensors	6 long blinks followed by short blinks that count the sensors	Off
Window sensors	7 long blinks followed by short blinks that count the sensors	Off
Keycard switches	8 long blinks followed by short blinks that count the switches	Off

Linking Activities

Activity	Power LED	Learn LED	Light Response
Link mode	Blinking	On solid	Cycles ON and OFF
Store link ID	On for 4 seconds, and then blinking	On solid	ON for 4 seconds, and then cycles
Clear link ID	Off for 4 seconds, and then blinking	On solid	OFF for 4 seconds, and then cycles

Test the Controller

Echoflex provides the controller in either a pre-commissioned state or a factory default state.

- Pre-commissioned devices are linked, configured, and labeled according to customer specifications. When powered, the red Power LED repeats a blink code to indicate the type and number of devices currently linked to the controller. To test, press the **[Learn]** button or use a linked switch.

Echoflex Installation Guide

LED Fixture Controller (120–277 VAC)

- In factory default state, when powered, the Power LED displays solid red to indicate the controller has no linked devices. To test, press the **[Learn]** button or link a switch. See relevant switch documentation.

A maximum of 20 switches or sensors can be linked to one controller.

Compliance

For complete regulatory compliance information, see the LED Fixture Controller (120–277 VAC) datasheet at echoflexsolutions.com or the Horticultural Luminaire Controller datasheet at rayngrowingsystems.com.

FCC Compliance

Echoflex LED Fixture Controller (120–277 VAC)

(For any FCC matters):

Echoflex Solutions, Inc.

3031 Pleasant View Road

Middleton, WI 53562

+1 (608) 831-4116

echoflexsolutions.com

This device complies with Part 15 of the FCC Rules. Operation is subject to the following two conditions: (1) this device may not cause harmful interference, and (2) this device must accept any interference received; including interference that may cause undesired operation.

This equipment has been tested and found to comply with the limits for a Class A digital device, pursuant to Part 15 of the FCC rules. These limits are designed to provide reasonable protection against harmful interference when the equipment is operated in a commercial environment. This equipment generates, uses, and can radiate radio frequency energy and, if not installed and used in accordance with the instructions, may cause harmful interference to radio communications. Any modifications or changes to this product not expressly approved by Electronic Theatre Controls, Inc. could void the user's authority to operate the product. Operation of this equipment in a residential area is likely to cause harmful interference, in which case the user will be required to correct the interference at their own expense.

Contains FCC ID: SZV-STM300U

ISED Compliance

This device contains a license-exempt transmitter/receiver that complies with Innovation, Science, and Economic Development Canada's license-exempt RSSs. Operation is subject to the following two conditions:

1. This device may not cause interference.
2. This device must accept any interference, including interference that may cause undesired operation of the device.

Contains IC ID: RSS 210

Conformité ISDE

Cet appareil contient un émetteur/récepteur conforme aux CNR d'Innovation, Sciences et Développement économique Canada (ISDE) applicables aux appareils radio exempt de licence. Son fonctionnement est soumis aux deux conditions suivantes:

1. L'appareil ne doit pas produire d'interférences.
2. L'utilisateur de l'appareil doit accepter toute interférence, même si l'interférence est susceptible d'en compromettre le fonctionnement.

Contient ID IC: RSS 210