

Echoflex Solutions Installation Guide

Elaho Relay Controller–Gen 2

Overview

The Elaho Relay Controller–Gen 2 offers fully-rated 20 A relays to switch lighting loads on and off. The Relay Controller–Gen 2 provides switching to individual fixtures or zone power.

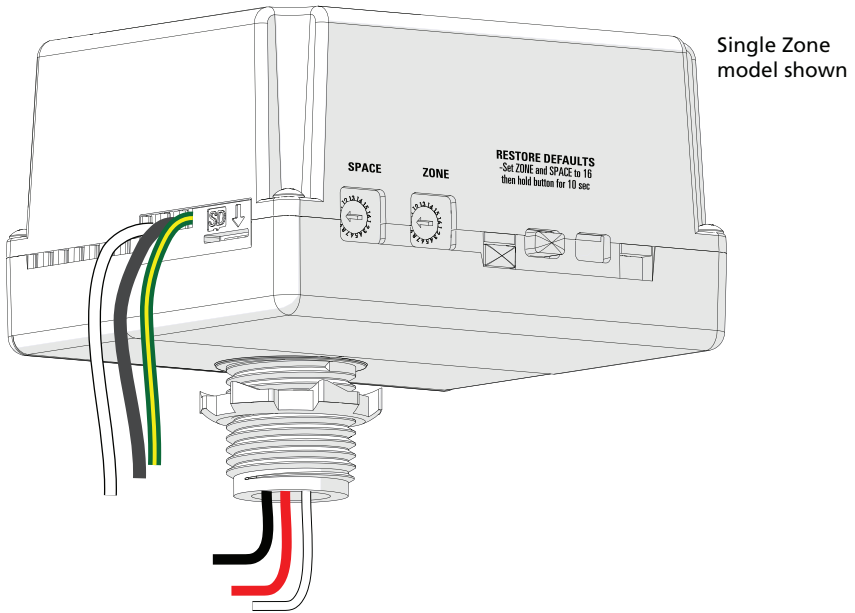

Two models are available:

- Single Zone (ERC-G2)
- Dual Zone (EDRC-G2)

The Relay Controller–Gen 2 controls lighting loads based on the following:

- Preset and Zone controls received from connected Elaho control stations
- Ambient light levels as monitored by Elaho Light Sensors
- Occupancy state as monitored by Elaho Occupancy/Vacancy Sensors
- Input from other Elaho control devices



Echoflex Solutions Installation Guide

Relay Controller–Gen 2

Custom Configuration

This document guides you through the installation and local configuration of the Relay Controller–Gen 2. You can access advanced functionality using the ElahoAccess Mobile App. For more information, see the ElahoAccess integrated help system.

EchoConnect

EchoConnect is a two-wire topology free system that provides the Relay Controller–Gen 2 with the flexibility to connect in a system with up to 16 Elaho control products and up to 15 other Elaho output products over 500 m (1,640 ft) of control wire.

Plug-and-Play Functionality

Using the Relay Controller–Gen 2 on the EchoConnect control system allows simple plug-and-play functionality, where no software or external programming is required. The connected control stations or sensors provide the control message and the Relay Controller–Gen 2 responds.

See the *Elaho Inspire Station Installation Guide*, *Elaho Occupancy/Vacancy Sensor Installation Guide*, or *Elaho Light Sensor Installation Guide* for more information about how to set levels and controls. You can download Echoflex Solutions manuals free of charge from the Echoflex Solutions website (see page 1).

Echoflex Solutions Installation Guide

Relay Controller–Gen 2

Specifications

For use with Echoflex Solutions dimming and relay products.

Ambient Environment

For indoor use only. Rated for plenum use.

- 32°F to 104°F (0°C to 40°C) operating temperatures in 5–95% non-condensing humidity

Electrical Specification

Single Zone model supports:

- Power input 120–277 VAC, 60 Hz
- Load rating:
 - 20 A general purpose, tungsten, or resistive
 - 16 A electronic ballast

Dual Zone model supports:

- Power input 120–277 VAC, 60 Hz
- Load rating:
 - 20 A general purpose, tungsten, or resistive
 - 16 A electronic ballast



Note: *The maximum load on the Dual Zone model can be split between the two relay outputs in any combination required for the installation, but cannot exceed the maximum load as specified above.*

Compliance

- cULus listed
- Conforms to:
 - UL 508 (Industrial Control Equipment)
 - UL 916 (Energy Management Equipment)
 - UL 2043 (Plenum rated)
 - CSA C22.2 No. 14 (Industrial Control Equipment)
 - CSA C22.2 No. 205 (Signal Equipment)

Echoflex Solutions Installation Guide

Relay Controller–Gen 2

Prepare for Installation

The Relay Controller–Gen 2 is designed for mounting directly to an electrical junction box or panel (provided by others) at the electrical lighting load, upstream of the load in the circuit.



Note: *If your installation requires Class 2 wiring to be installed in separate conduit, a voltage barrier installation box is available from Echoflex Solutions. Order Echoflex Solutions part number 7187A1000.*

EchoConnect Control Wiring

The Relay Controller–Gen 2 connects to the EchoConnect station communication bus for control. EchoConnect is a bidirectional protocol that uses one pair of wires (data + and data -) for both data and power. Echoflex Solutions recommends using Belden 8471 (or approved equal) Class 2 wire. The total combined length of an EchoConnect wire run (using Belden 8471, or equal) may not exceed 500 m (1,640 ft).



Note: *All control wiring should be installed and terminated by a qualified installer and should follow standard wiring installation practices. Leave approximately 20 cm (8 in) of wiring in the back box for connection and to allow slack for future service needs.*



Note: *Echoflex Solutions requires that all Elaho stations and devices be grounded for ESD protection. Pull an additional 2.5 mm² (14 AWG) wire for grounding when control wires are not installed in grounded metal conduit.*

Echoflex Solutions Installation Guide

Relay Controller–Gen 2

Installation

Installation should follow all local codes and standard electrical practices. Ensure that the junction box is clean and free of obstructions and that all wiring is installed correctly.



WARNING: Risk of electric shock! This device utilizes high voltage and should only be installed by a qualified installer or electrician. Follow all local codes for installation. Before terminating the AC power wiring verify that the main breaker is in the off position and follow the proper lockout/tag out procedures per NFPA Standard 70E.

AVERTISSEMENT: Risque de décharge électrique! Cette appareil utilise une haute tension et ne doit être installé que par un installateur qualifié ou un électricien. Suivez tous les codes locaux pour l'installation. Avant de raccorder le câblage du courant alternatif, vérifiez que le disjoncteur principal est en position d'arrêt et suivez les procédures de Consignation/Déconsignation prescrites par la norme NFPA 70E.



WARNING: For indoor use only! Must install to an electrical junction box or wireway.

AVERTISSEMENT: Uniquement pour usage d'intérieur! Doit être installé sur une boîte de raccordement électrique ou un chemin de câbles.

1. Locate the circuit breaker panel and turn off the power to the lighting circuit.
 2. To gain access to the line voltage wiring, remove the cover plate and other hardware from the junction box at the load.
 3. Mount the Relay Controller–Gen 2 to the exterior of the junction box or panel using the 1/2 in threaded nipple. Use the provided 1/2 in conduit locknut to secure the Relay Controller–Gen 2 to the junction box or panel.
-



Note: *Follow all local code requirements for terminating wire.*

- *Notice that the harness wires on the controller are pre-stripped for your installation convenience.*
 - *Use appropriately sized wire nuts (not provided) to terminate power wires, and use included WAGO® connectors to terminate EchoConnect wires.*
-

Echoflex Solutions Installation Guide

Relay Controller–Gen 2

Connect EchoConnect

The EchoConnect wire terminations are bound together and include a black wire (data -), a white wire (data +), and a green/yellow wire (ESD). Because EchoConnect is topology free, you can install the wires in any combination of bus, star, loop, or home-run.



Note: When using Category5 (or equivalent) cable on the EchoConnect communication bus, please note the following:

- Not all topologies are supported using Cat5; plan carefully to ensure that the proper termination kits are available and the wire is pulled appropriately.
- Terminate Cat5 wiring using the EchoConnect Cat5 Station Termination Kit, and install it using a bus topology. See the installation guide that is provided with the Cat5 Station Termination Kit (8186A1707) for information on terminating Cat5 wiring.

1. Pull all required wiring (data +, data -, and the ESD ground wire) to the junction box.
2. Use the included WAGO connectors to make the following terminations:
 - a. Connect the incoming ground wire to the ESD green/yellow ground wire on the unit.
 - b. Connect the white (data +) wire to the incoming data + (typically white).
 - c. Connect the black (data -) wire to the incoming data - (typically black).

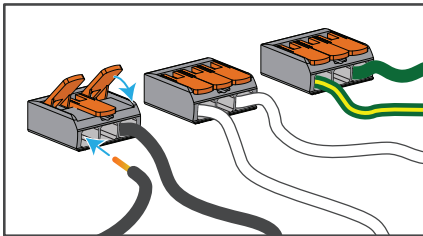

Terminate EchoConnect wiring using provided WAGO connectors.

Echoflex Solutions Installation Guide

Relay Controller–Gen 2

Connect Power Input and Relay Output

The power input and relay output wiring exits the Relay Controller–Gen 2 through the knockout mount on the enclosure.

1. Connect the power input wiring.
 - a. Connect the white wire (14 AWG) to the incoming neutral wire from the breaker panel and the neutral wire of the lighting load.
 - b. Connect the black power input wire (12 AWG) to the line input feed wire (hot) from the breaker panel.
2. Connect the relay output wiring. A Single Zone controller has one (red) relay output wire (12 AWG). A Dual Zone controller has two relay output wires (12 AWG): Zone 1 is red and Zone 2 is red/white.
 - a. Connect the Zone 1 relay output wire (red) to the hot input of the load.
 - b. For the Dual Zone controller, connect the Zone 2 relay output wire (red/white) to the hot input of the second load.

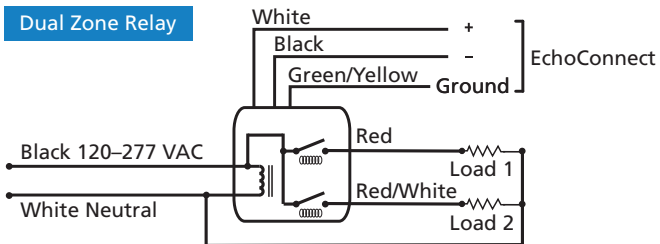
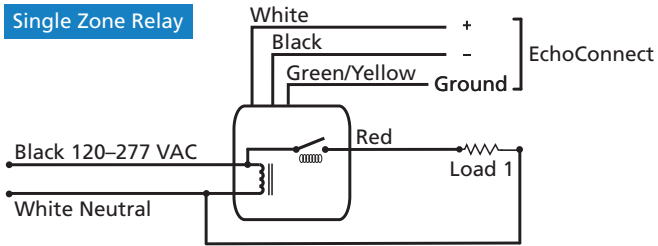

3. Reinstall the junction box cover plate.

Echoflex Solutions Installation Guide

Relay Controller–Gen 2

Assign Zones and Spaces

You can assign zones and spaces using the two rotary switches on the side panel of the controller.

The Dual Zone controller assigns two zones by using the Zone switch setting as the first zone assignment and then automatically assigning the next consecutive zone number for the second zone.

By default, these switches are set to Zone 1, Space 1. Control inputs from the connected stations, sensors, and other controls are shared by all devices within a space.

1. Set the **Zone** rotary switch to the desired Zone address for this controller.

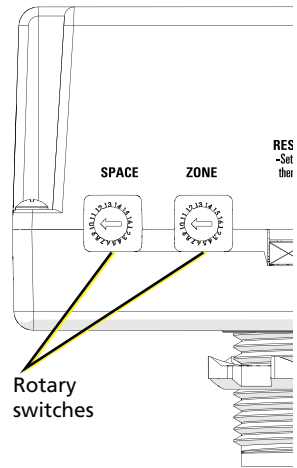

Note: For the Dual Zone model only, do not set the Zone switch setting to a number higher than 15. If set to 16, both circuits in the controller will be assigned to and controlled on Zone 16.

2. Set the **Space** rotary switch to the desired Space for this controller.

Echoflex Solutions Installation Guide

Relay Controller–Gen 2

Power Up and Test

1. Restore power to the circuit. The Relay Controller–Gen 2 will power up and turn on all connected loads to full output.
2. Test the circuit by activating the associated Elaho station preset or by changing the zone intensity control.
3. Test the controller response. Use station controls to alter preset or zone status, and ensure that the Relay Controller–Gen 2 responds.

Power-Up Behavior

In the event of a power loss to the Relay Controller–Gen 2, the controller will return to its last output level when power is restored.

Troubleshooting

Restore Defaults

To return the Relay Controller–Gen 2 to factory defaults, set both rotary switches to 16 and then press and hold the **Restore Defaults** button for 10 seconds. The LED will blink red quickly to indicate that the factory defaults have been restored.



Note: *After you return the Relay Controller–Gen 2 to factory defaults, reset the rotary switches to the appropriate values for the controller zone and space.*

Echoflex Solutions Installation Guide

Relay Controller–Gen 2

Update Firmware

If updated firmware is required, you can update the firmware on the Relay Controller–Gen 2 by using ETC UpdaterAtoR software and a microSD card. You can download UpdaterAtoR from the ETC website at etconnect.com.



Note: Plan to update firmware when troubleshooting any issues with the Relay Controller–Gen 2.

1. Get the firmware update file using UpdaterAtoR.
2. Save the firmware update file to the root directory of a microSD card.
3. Ensure that power is supplied to the controller.
4. Insert the microSD card in the SD slot on the side of the Relay Controller–Gen 2 enclosure.
 - The **Dim Mode** LED will illuminate amber in a triple-blink pattern while the firmware is updating, and then will return to its previous state when the update is complete.
 - If the LED illuminates red in a double-blink pattern, an error has occurred. Ensure that the firmware file has not been renamed and is located at the root directory on the microSD card, and then attempt the firmware update again. If the LED continues the double-blink pattern, contact Echoflex Solutions Technical Services using the information at the bottom of page 1.
5. When the LED returns to its previous state, remove the microSD card.

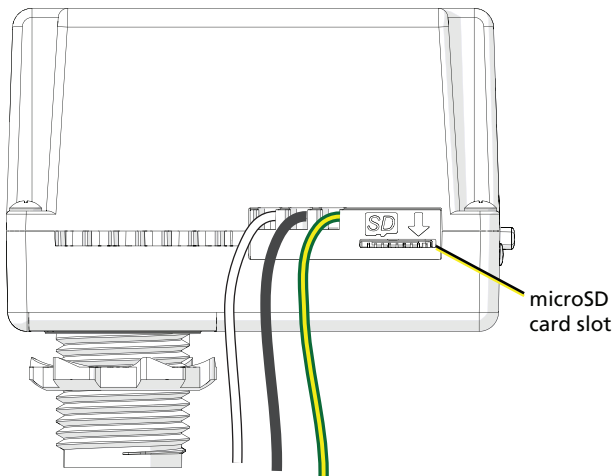

Echoflex Solutions Installation Guide

Relay Controller–Gen 2

Echoflex Solutions Installation Guide

Relay Controller–Gen 2
