

### Overview

The Resonate family of temperature and relative humidity sensors have been designed to provide a reliable and simple method to set up intelligent automation of interior spaces for energy savings.

The Resonate family sets a new bench mark in temperature accuracy and update speed of temperature changes. The units are accurate to 0.3°C and 3% relative humidity. These sensors are suitable for Variable Volume Temperature (VVT) or Variable Air Volume (VAV) forced air systems.

Batteries are not required for everyday operation due to the advanced solar energy harvesting and power management features of the sensor. Upon installation, the sensor will operate with exposure to 200 Lux (20 fc) in as little as 2 minutes. The RTS is capable of operating up to 200 hours in darkness from maximum charge levels.

The RTS sensor incorporates our latest diagnostic and configuration features to ensure reliable communications and solar harvesting capability. The RTS supports Range Confirmation® technology whereby simple button press and hold sequences result in LED indication of signal strength. Solar energy harvesting level indication under existing light levels is also provided on demand through LED indication.

These built-in features assist the installer to position the sensor and be confident of its operation without using separate light meters and signal strength indicators.

\*Note: Range Confirmation® requires an “F” series of Echoflex controller (“F” series is exclusive to 902 MHz at this time).



### Features

- Solar powered wireless temperature and optional relative humidity sensor
- Temperature accuracy of 0.5°F/ 0.3°C
- Relative Humidity accuracy of 3%
- Integrated Range Confirmation® via tricolored LED indication
- Integrated solar harvesting light level LED indication
- Reliable radio reception range of 24 m (80 ft) - commercial office spaces (typical), up to 100m (330 ft) line of sight
- Quick start-up operation, 2 minutes @ 200 lux
- Up to 200 hours operation in complete darkness
- Operates in low light conditions, 15 lux (2 fc)
- Occupancy override button (in RTS-2HS models)
- Optional battery start assist

### Ordering Information

Description	902 MHz Models	902 MHz PN	868 MHz Models	868 MHz PN
Temperature Sensor	RTS-1T-UW	8188A1174-X-1	RTS-1T-YW	8188A1374-X-1
Temperature Sensor with setpoint	RTS-1TS-UW	8188A1175-X-1	RTS-1TS-YW	8188A1375-X-1
Temperature Sensor with relative humidity (RH)	RTS-1H-UW	8188A1176-X-1	RTS-1H-YW	8188A1376-X-1
Temperature Sensor with fan speed, RH and setpoint	RTS-2HS-UW	8188A1179-X-1	RTS-2HS-YW	8188A1379-X-1

Note: Other models are available by special order - please contact us for details

## Dimensioned Diagram

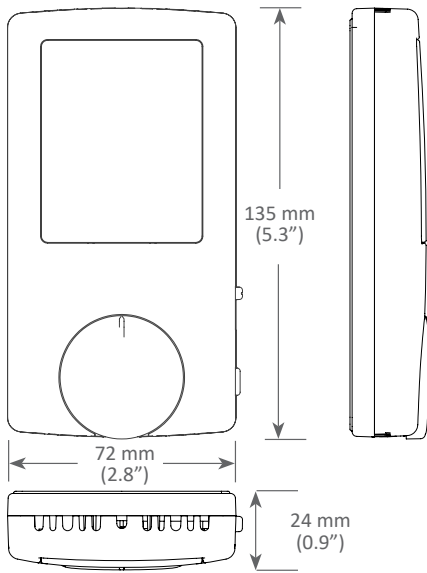

## Block Diagram

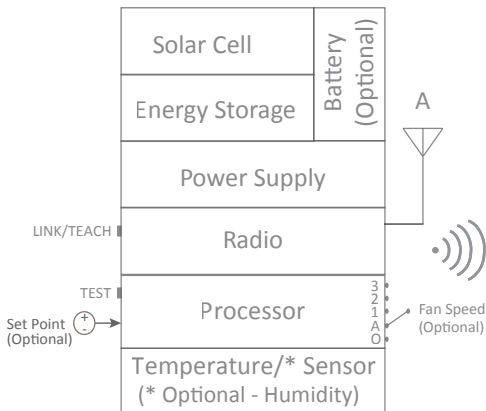

## Agency Listing & Compliance

### 902 MHz Models

FCC Part 15.231 - Remote Control Transmitter  
IC RSS-210



### 868 MHz Models

CE Marking



## Equipment Profiles

EEP A5-02-05	Temperature Sensor
EEP A5-10-03	Temperature + Set Point
EEP A5-04-01	Temperature + Humidity
EEP A5-10-19	Temperature + Humidity + Set Point + Fan Speed + Occupancy Button

Note: Other profiles are available by special order - please contact us for details

## Hardware Specifications

<b>Temperature</b>	0°C to 40°C (32°F to 104°F) range
	0.3°C (0.5°F) accuracy
<b>Humidity Sensor</b>	20 to 95% range, 3% accuracy
	0.4% resolution
<b>Power Supply</b>	Integrated solar cell
Operational light level	15 lux (2 fc)
Minimum charge time to begin operation	2 minutes @ 200 lux (20 fc)
Charging Light Level	above 100 lux (10 fc)
Maintain charge time	2 hours per 24 hours @ 200 lux (20 fc)
Maximum charge time	6 hours at 200 lux (20 fc)
Operating life at full charge	200 hours @ 0 lux
Battery - start assist	CR2032 coin cell (optional - not included)
<b>Inputs</b>	Teach Button, Test Button, Set Point Dial*, Fan Speed Switch* *Not all models
<b>Outputs</b>	Test mode LEDs - red, green, and amber

## Communications

<b>Radio Frequency</b>	902 MHz(U) or 868 MHz(Y)
<b>Antenna</b>	Integrated whip
<b>Transmission Range</b>	24 m (80 ft) - commercial office spaces(typical), up to 100m (330 ft) line of sight

## Temperature Monitoring

	Sampling Rate	Telegram Period
Light level > 100 lux (10 fc)	10 seconds	on 0.3°C (0.5°F) change or 10 samples or 3% humidity change
Light level < 100 lux (10 fc)	100 seconds	
After 24 hrs @ < 15 lux (2 fc)	200 seconds	

## Mechanical Specifications

<b>Operating Temperature</b>	-25°C to 65°C (-13°F to 145°F)
<b>Relative Humidity</b>	5% to 92% RH (non-condensing)
<b>Weight</b>	130 g (4.5 oz)
<b>Dimensions</b>	135 x 72 x 24 mm (5.3 x 2.8 x 0.9")
<b>Mounting</b>	screws or double sided tape (not supplied)

Specifications are subject to change without notification. | Range Confirmation is an Echoflex Solutions Inc. Patented Technology