

Pushbutton Transmitter Device 315 MHz PTM 200C

January 19, 2009



REVISION HISTORY

The following major modifications and improvements have been made to the first version of this document:

No	Major Changes
V1.01	Note added in chapter 1.4: Movement of energy bows must not be limited by mounted rockers
V1.02	Section 3.6 Japanese Type Approval added

Published by EnOcean GmbH, Kolpingring 18a, 82041 Oberhaching, Germany
www.enocean.com, info@enocean.com, phone ++49 (89) 6734 6890

© EnOcean GmbH
 All Rights Reserved

Important!

This information describes the type of component and shall not be considered as assured characteristics. No responsibility is assumed for possible omissions or inaccuracies. Circuitry and specifications are subject to change without notice. For the latest product specifications, refer to the EnOcean website: <http://www.enocean.com>.

As far as patents or other rights of third parties are concerned, liability is only assumed for modules, not for the described applications, processes and circuits.

EnOcean does not assume responsibility for use of modules described and limits its liability to the replacement of modules determined to be defective due to workmanship. Devices or systems containing RF components must meet the essential requirements of the local legal authorities.

The modules must not be used in any relation with equipment that supports, directly or indirectly, human health or life or with applications that can result in danger for people, animals or real value.

Components of the modules are considered and should be disposed of as hazardous waste. Local government regulations are to be observed.

Packing: Please use the recycling operators known to you. By agreement we will take packing material back if it is sorted. You must bear the costs of transport. For packing material that is returned to us unsorted or that we are not obliged to accept, we shall have to invoice you for any costs incurred.



TABLE OF CONTENT

1 GENERAL DESCRIPTION 4

1.1 Basic Functionality..... 4

1.2 Typical Applications 5

1.3 Technical Data 5

1.4 Mechanical Interface..... 5

1.5 Environmental Conditions 10

1.6 Ordering Information 10

2 FUNCTIONAL DESCRIPTION 10

2.1 Block Diagram 10

2.2 Contact Nipples Designation 11

2.3 PTM 200C Radio Telegram 12

2.3.1 Frequency range 12

2.3.2 Modulation process 12

2.3.3 Transmission timing 12

2.3.4 Reliable radio transmission within systems operating many sensors 13

3 APPLICATIONS INFORMATION..... 14

3.1 Laying the antenna 14

3.2 Construction of application specific Switch Rockers..... 15

3.3 Device Mounting 15

3.4 Transmission Range 16

3.5 FCC/IC Approval Requirements 17

3.6 Japanese Type Approval..... 20

4 DEVELOPMENT TOOLS 21

4.1 Evaluation Kit EVA 105C..... 21

4.2 Field Intensity Meter EPM 100C 21

5 PATENT PROTECTION 22

1 GENERAL DESCRIPTION

The radio transmitter device PTM 200C from EnOcean enables the implementation of wireless remote controls without batteries. Power is provided by a built-in electro-dynamic power generator.

The PTM 200C device serves the 315 MHz air interface protocol of EnOcean. Together with the receiver device RCM 130C, this device can be easily integrated in operation and control units for the implementation of different application specific system solutions.

(1) Energy bow
on both device sides

(2) Contact nipples
for switch rocker
identification

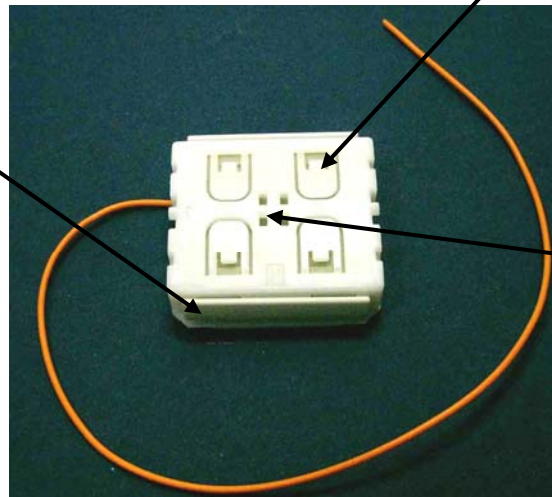

Rotation axis for
pushbuttons or
switch rocker

Figure 1: Electro-dynamic powered radio transmitter device PTM 200C

1.1 Basic Functionality

A common electro-dynamic energy transducer is actuated by a bow (1), which can be pushed from outside the device by an appropriate push button or switch rocker. When the energy bow is pushed down, electrical energy is created and an RF telegram is transmitted including a 32-bit device ID. Releasing the energy bow generates different telegram data, so every PTM telegram contains the information that the bow was pressed or released.

“Long” or “Short” push button operation (the time between pushing and releasing the pushbutton) can be easily detected by the receiver. By doing that, applications such as dimming control or blinds control including slat action are simple to implement.

In addition, the PTM telegram transmits the operating status of the contact nipples (2) when pressing the bow. This enables the identification of up to 2 appropriate switch rockers or up to 4 pushbuttons.

1.2 Typical Applications

- Building installation
- Industrial automation
- Consumer electronics

Key applications are wall-mounted flat rocker switches with 1 or 2 rockers, as well as hand-held remote controls with up to 4 single pushbuttons. Because the RF transmitters are self-powered (no batteries), maintenance-free RF systems are possible.

1.3 Technical Data

Power supply	power generation by rocker operating (Electrodynamic Power Generator)
Antenna	external whip antenna 26.8 cm, $\varnothing 1.3^{\pm 0.1}$ mm
Frequency / Transmission power	315.0 MHz / typ. 3dBm at antenna input
Data rate / Modulation type	125 kbps / ASK
Channels	2 with 4 action states each (upper/lower pushbutton is pressed/released)
Telegram type	RPS of type 2 (allows interpretation of operating two buttons simultaneously)
Transmission range	300m free field, typ. 30m indoor
Telegram packet length (sub telegram)	0.7 ms +/- 5%
Number of channels	2 channels with action states each (upper/lower contact nipple is pressed/released)
Device-identifier	individual 32-bit ID (factory programmed)
No. of (redundant) packets	3 – 5 (depending on residual energy) 3 packets within about 20 ms, delay effected at random

1.4 Mechanical Interface

Module dimensions (inclusive rotation axis and energy bow)	40.0 x 40.0 x 11.2 mm
Device weight	20 g \pm 1g
Energy bow travel / operating force	1.8 mm / approx. 7 N *)
	*) at room temperature, only one energy bow may be actuated at the same time!
Restoring force at energy bow	0.5N to 4N
	For the correct function of the application, the specified minimal restoring force of 0.5N must be considered!
Number of operations	typ. 50.000 actuations tested according to VDE 0632 / EN 60669
Cover material	Hostaform (POM)
Energy bow material	PBT (50% GV)

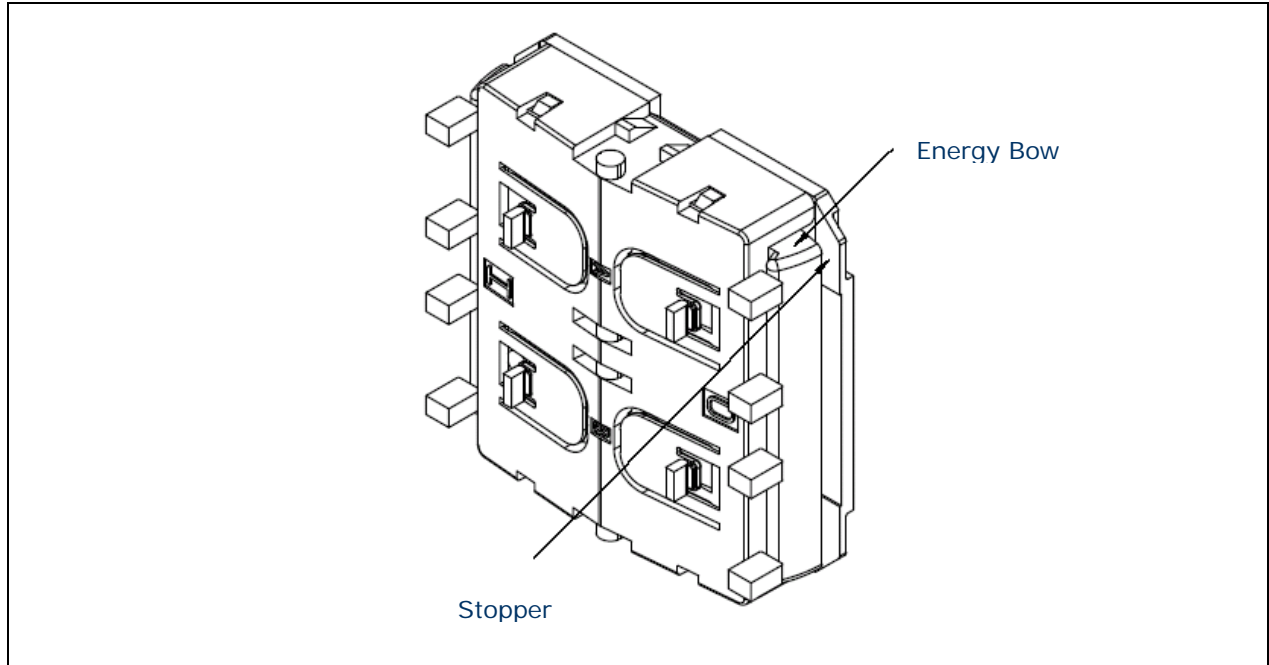
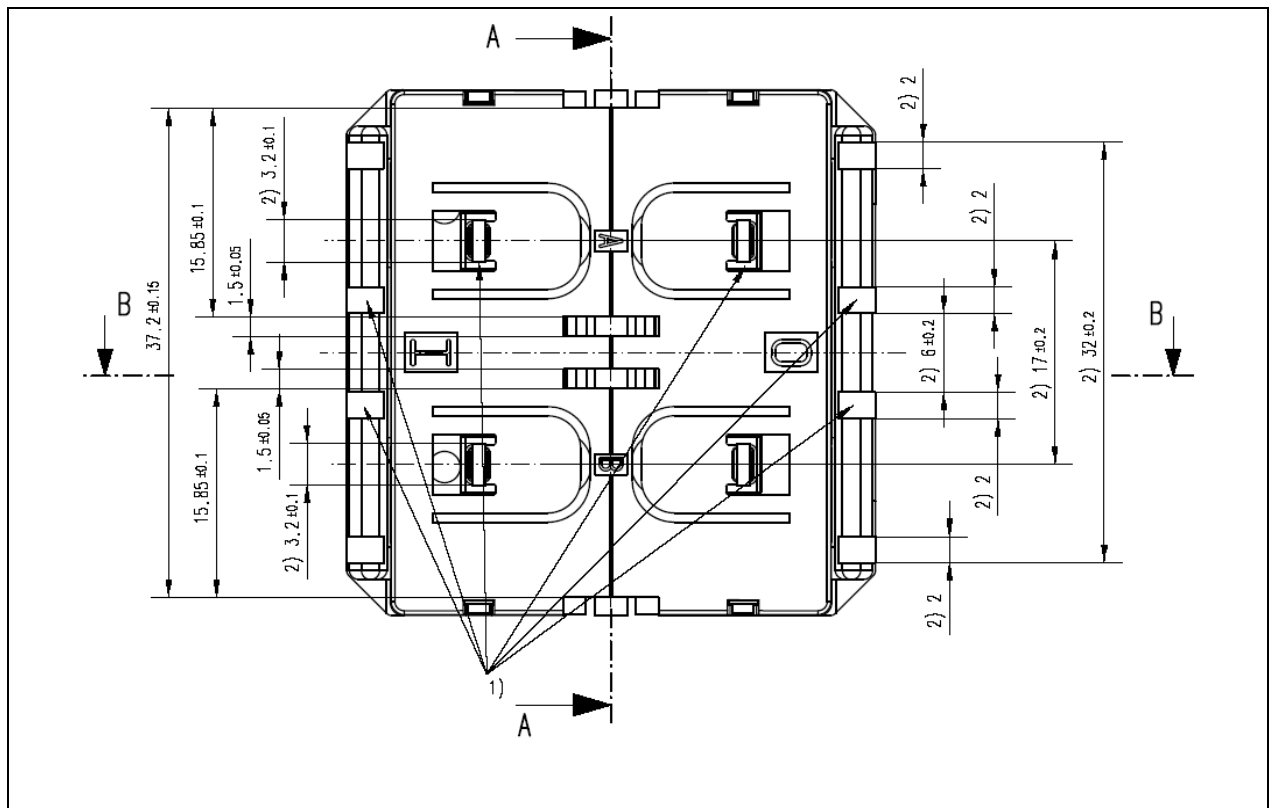

Figure 2: PTM 200C without antenna, tilted view (including rocker catwalks)



1) this catwalks are not needed when using one single rocker only 2) dimensions of rocker part

Figure 3: PTM 200C without antenna, top view (note cut A, B and C marking)

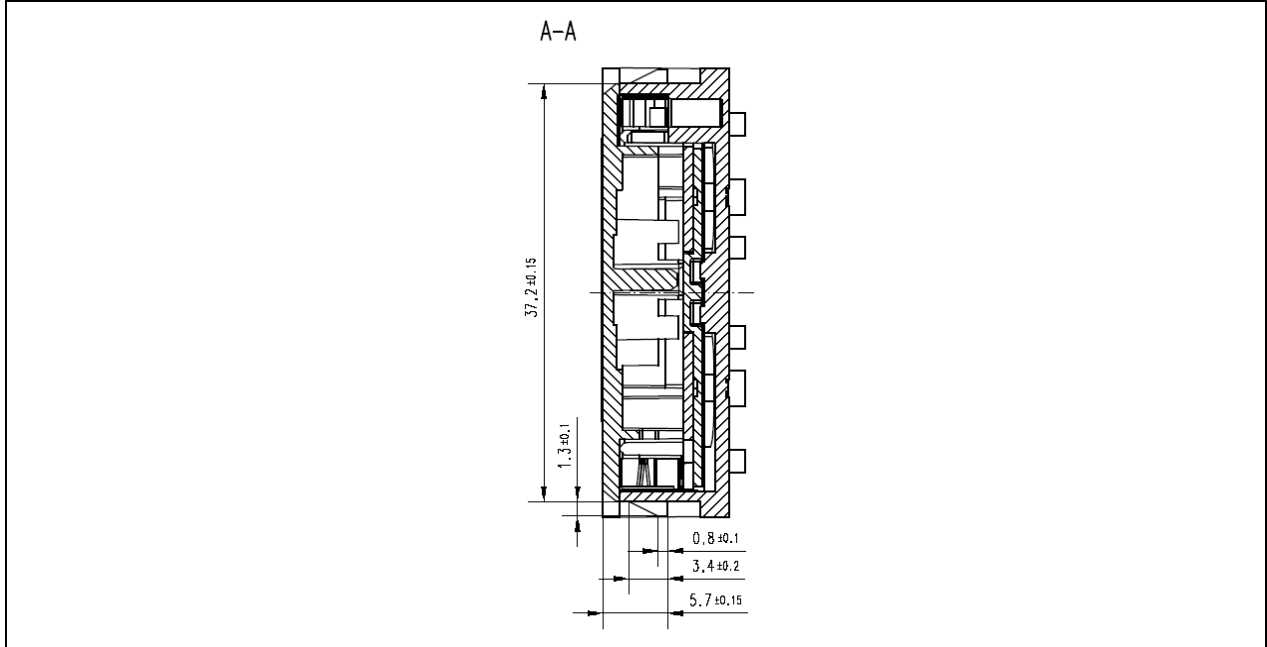
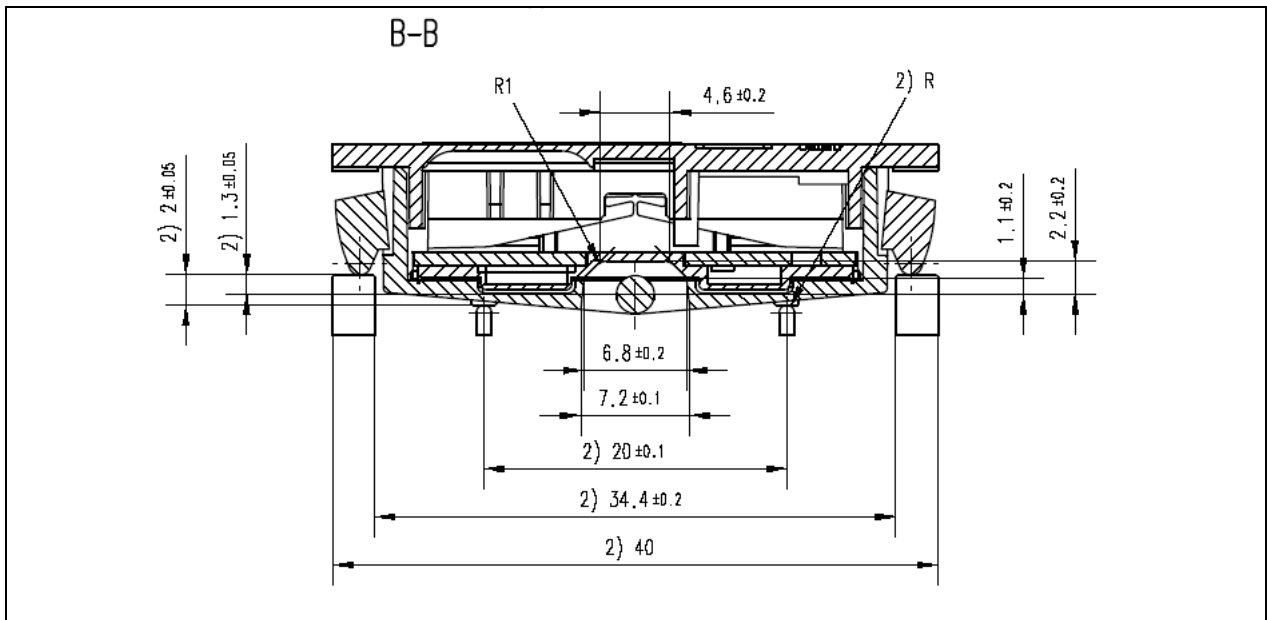
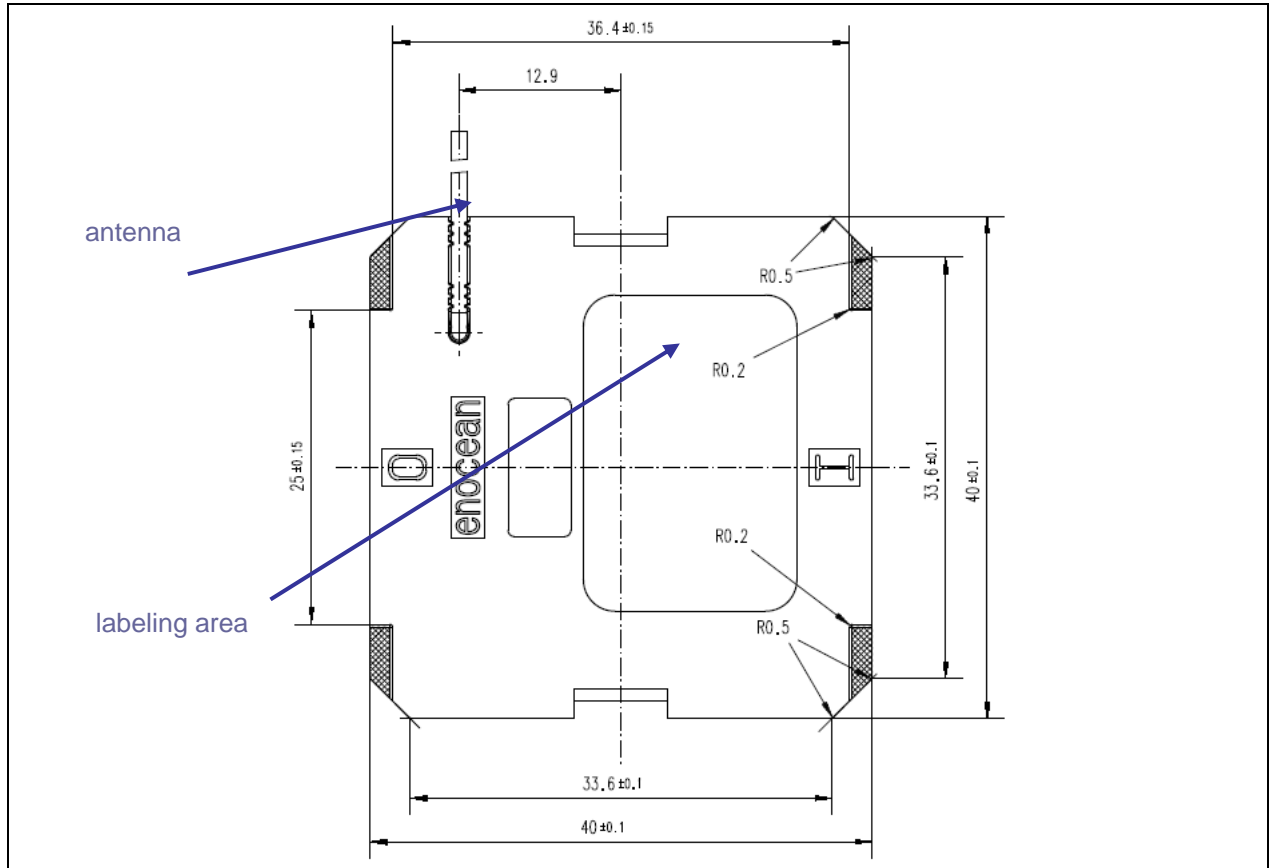

Figure 4: PTM 200C without antenna, cut A



2) dimensions of rocker part

Figure 5: PTM 200C without antenna, cut B and C



Hatched areas: support planes

Figure 6: PTM 200C with antenna, rear view

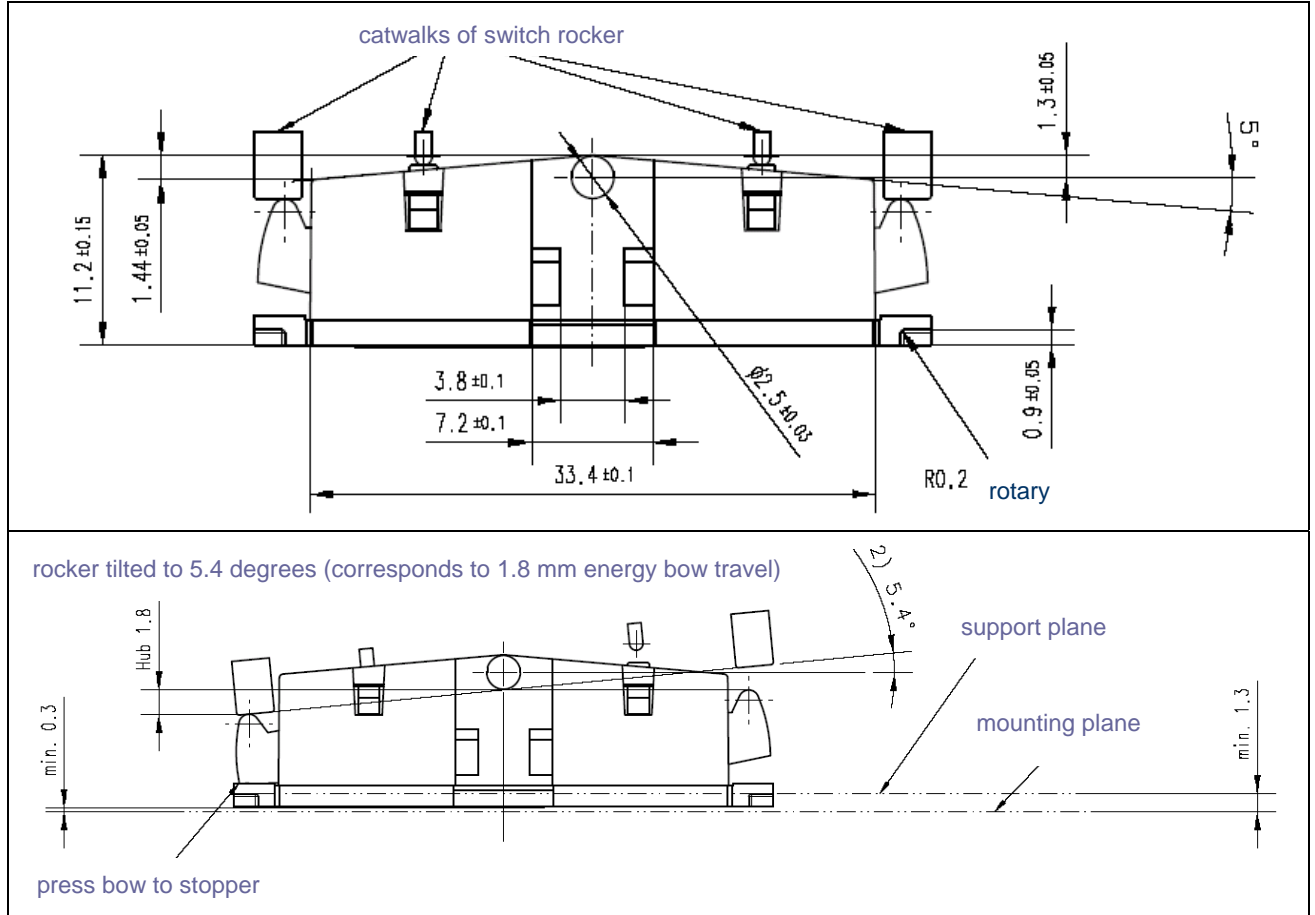

2) dimensions of rocker part

Figure 7 and 8: PTM 200C without antenna, side view



If the rocker is not mounted on the rotation axis of PTM200C several tolerances have to be considered!

The measure from support plane to top of the energy bow is 7.70 mm +/- 0.3 mm!



The movement of the energy bow must not be limited by mounted rockers!

1.5 Environmental Conditions

Operating temperature	-25°C up to +65 °C
Storage temperature	-25°C up to +65 °C
Humidity	0% to 95% r.h.

1.6 Ordering Information

Type	Ordering Code
PTM 200C	S3031-A200

2 FUNCTIONAL DESCRIPTION

2.1 Block Diagram

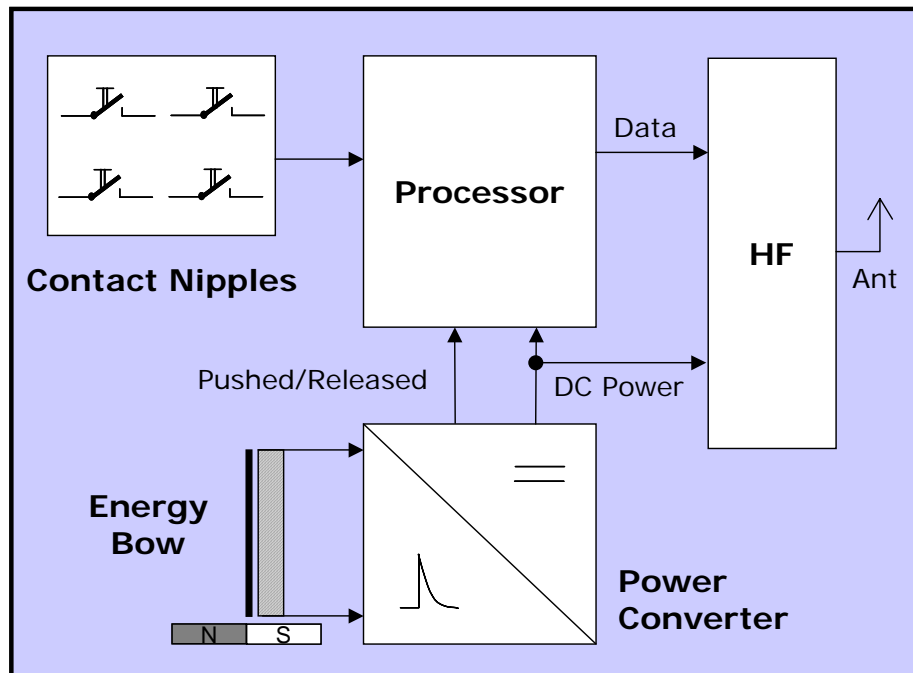

Figure 9: Block diagram of PTM 200C

Energy Bow / Power Generator

Converts pressure on the energy bow into electrical energy.

Power Converter

Electronic converter unit for generating the device DC power supply

Processor

Converts the contact nipples' status and pushed/released data from the power generator into a reliable and energy-efficient serial telegram structure.

HF transmitter

Sends the data in the form of a series of short radio signals.

2.2 Contact Nipples Designation

With 4 contact nipples, the PTM 200C offers 2 channels with 4 action states each (upper/lower nipple is pressed/released when activating the energy bow). The nipples' designation is as follows:

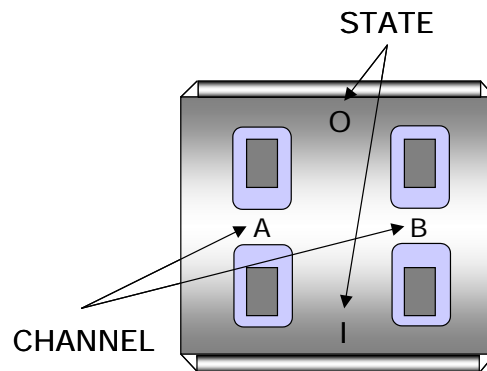

Figure 10: Contact nipple designation

Radio signals of the PTM 200C device are event-controlled (energy bow is pressed/released) with contact nipple code (channel/state) and unique device identification (fixed 32-bit ID). When operating more than one nipple at the same time, note that PTM 200C sends multiple-button code combinations:

- **N-message: One or two contact nipples have been pressed** when activating the energy generator → Message with nipple code and pressed/released event status of the energy bow is sent.
- **U-message: No contact nipple was pressed** when activating the energy generator, **or 3 or 4 nipples have been pressed** → Message with pressed/released event status of the energy bow is sent and the information if either none or more than two nipples have been pressed. Note that it can't be differentiated if 3 or if 4 nipples have been pressed.

Note: Due to the mechanical hysteresis of the energy bow, in most rocker switch device implementations, pressing the rocker sends an N-message and releasing the rocker sends a U-message!

2.3 PTM 200C Radio Telegram

For the transmission of the telemetric signals, EnOcean has defined a new dynamic radio data telegram that is adapted to the individual application. It is optimized to the essential features of energy autarkic radio sensors:

- Minimal energy demand
- Possibility of operating hundred of senders within the same radio cell
- Maximum transmission reliability
- Wide transmission range
- Easy extensibility
- Suitable for uni- and bi-directional communication
- Flexibility for adaptation of different data structures and data quantities
- Data encryption option

2.3.1 Frequency range

The EnOcean PTM200C operates at 315.0 MHz.

2.3.2 Modulation process

As modulation process, EnOcean uses incoherent amplitude modulation (ASK). Digital amplitude modulation enables the implementation of very efficient energy-saving transmitters because only the "1"-bits are transferred. At the same interference signal level, the transmission security of the alternative FSK method is identical to that of the ASK method .

2.3.3 Transmission timing

The transmission timing of the radio device PTM 200C has been developed to avoid possible collisions with data packages of other EnOcean transmitters as well as disturbances from the environment.

With each transmission cycle, at least three identical subtelegrams are transmitted. The transmission of a subtelegram lasts approximately 0.7 ms. To optimize data security, each telegram is repeated twice within about 20 ms, whereas the delay between the second and the third transmission burst is effected at random. If some residual energy is available after transmission of three subtelegrams, up to 2 further subtelegrams are sent.

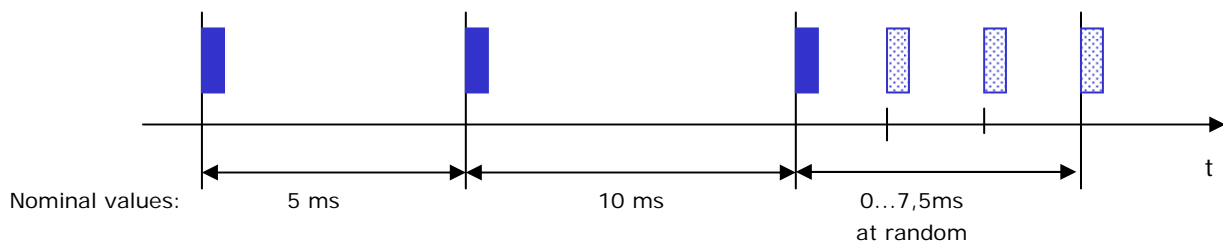

Figure 11: PTM 200C radio timing

2.3.4 Reliable radio transmission within systems operating many sensors

The very short telegrams of EnOcean transmitters enable the operating of a large number of transmitters within the same radio cell; the error rate caused by telegram collisions remains extremely low. Statistically viewed, the transmission reliability is still greater than 99.99% in the case of 100 radio sensors that transmit once every minute. This means that even large office buildings and also huge industrial facilities can be equipped with a large number of sensors of this kind of radio technology.

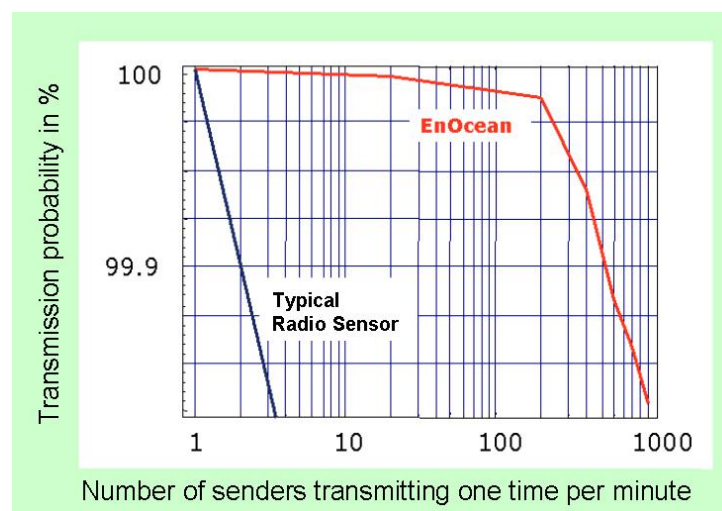

Figure 12: Probability of transmission failure caused by radio data collision for EnOcean light switch transmitter PTM 200C

3 APPLICATIONS INFORMATION

3.1 Laying the antenna

For best performance the antenna cable should be laid as shown in the figure below.

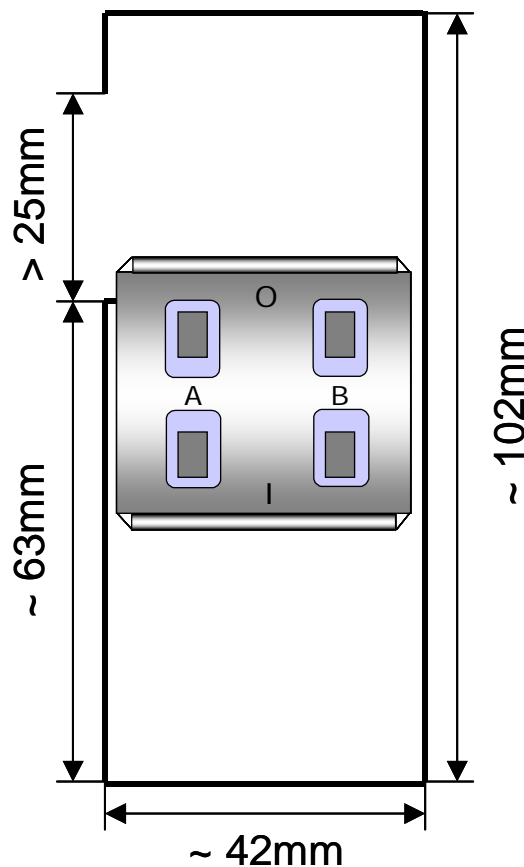

Figure 13: Laying the antenna

Important note:

- The distance between antenna foot point and antenna end must be > 25mm
- The antenna area should be maximized
- The antenna should be placed at the same height above the ground plane as the rotation axis for the switch rocker (see example below)

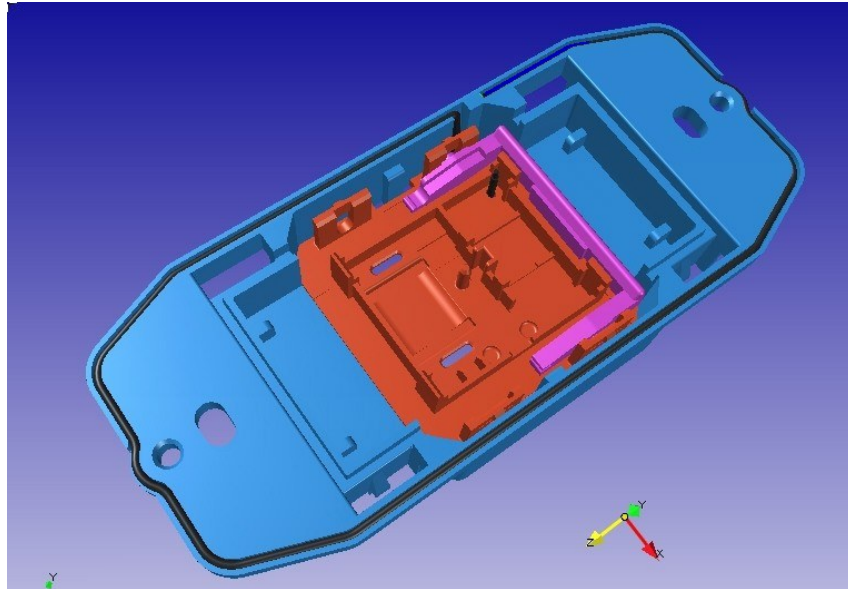

Figure 13: Example of a well suited antenna

3.2 Construction of application specific Switch Rockers

For CAD system development support, 3D construction data is available from EnOcean (IGS data). Using this data, the mechanical interface is fixed, and the shape and surface of the rocker(s) can be changed according to requirements. Recommendation for suitable rocker material is Ultradur B 4520 with a surface roughness of min. Ra 1.0 μm .

**Please note that the rockers should be of nonmetal for best transmission range!
Please also avoid plastic materials with conducting ingredients like graphite!**

3.3 Device Mounting

For mounting the PTM 200C device into an application specific case, the package outline drawings of the device are roughly dimensioned in chapter 1.4. If more detailed dimensioning data of the PTM 200C device case is necessary, 3D construction data is available from EnOcean (IGS data).

3.4 Transmission Range

The main factors that influence the system transmission range are:

- Type and location of the antennas of receiver and transmitter
- Type of terrain and degree of obstruction of the link path
- Sources of interference affecting the receiver
- “Dead” spots caused by signal reflections from nearby conductive objects

Since the expected transmission range strongly depends on these system conditions, range tests should categorically be performed in early project phases!

The following figures for expected transmission range are considered by using a PTM, or STM transmitter device and the RCM radio receiver device with preinstalled whip antenna and may be used as a rough guide only:

- ***Line-of-sight connections:*** Typically 30m range in corridors, up to 100m in halls
- ***Plasterboard walls / dry wood:*** Typically 30m range, through max. 5 walls
- ***Brick walls / aerated concrete:*** Typically 20m range, through max. 3 walls
- ***Ferroconcrete walls / ceilings:*** Typically 10m range, through max. 1 ceiling
- ***Fire-safety walls, elevator shafts, staircases and supply areas should be considered as screening.***

The angle at which the transmitted signal hits the wall is very important. The effective wall thickness – and with it the signal attenuation – varies according to this angle. Signals should be transmitted as directly as possible through the wall. Wall niches should be avoided. Other factors restricting transmission range:

- **Switch mounted on metal surfaces (up to 60% loss of transmission range)**
- **Hollow lightweight walls filled with insulating wool on metal foil**
- **False ceilings with panels of metal or carbon fiber**
- **Lead glass or glass with metal coating, steel furniture**

The distance between EnOcean receivers and other transmitting devices such as computers, audio and video equipment that also emit high-frequency signals should be at least 1m.

A summarized application note to determine the transmission range within buildings is available as download from www.enocean.com.

3.5 FCC/IC Approval Requirements

This device complies with Part 15 of the FCC Rules and with RSS-210 of Industry Canada. If this device is operated in compliance with the following requirements **it can be operated without notification and free of charge in the area of the United States of America and in Canada**. Operation is subject to the following two conditions:

- (1) this device may not cause harmful interference, and
- (2) this device must accept any interference received, including interference that may cause undesired operation.

Trade Name: PTM200C
 Model No: PTM200C

FCC ID: SZV-PTM200C
 IC: 5713A-PTM200C



This device complies with Part 15 of the FCC Rules and with RSS-210 of Industry Canada. Operation is subject to the following two conditions. (1) this device may not cause harmful interference, and (2) this device must accept any interference received, including interference that may cause undesired operation.

Warning: Changes or modifications made to this equipment not expressly approved by EnOcean may void the FCC authorization to operate this equipment.

This equipment has been tested and found to comply with the limits for a Class B digital device, pursuant to Part 15 of the FCC Rules. These limits are designed to provide reasonable protection against harmful interference in a residential installation.

This equipment generates, uses and can radiate radio frequency energy and, if not installed and used in accordance with the instructions, may cause harmful interference to radio communications.

However, there is no guarantee that interference will not occur in a particular installation. If this equipment does cause harmful interference to radio or television reception, which can be determined by turning the equipment off and on, the user is encouraged to try to correct the interference by one or more of the following measures:

- Reorient or relocate the receiving antenna.
- Increase the separation between the equipment and receiver.
- Connect the equipment into an outlet on a circuit different from that to which the receiver is connected.
- Consult the dealer or an experienced radio/TV technician for help.

Due to FCC 15.231 operational and timing requirements the PTM 200C switch device **must not be operated more than 1088 times per hour** (pushed or released as one operation each):

- Total duration of transmissions must not exceed more than two seconds per hour
- PTM 200C packet length is 0.7 ms, max. 5 redundant packets, tolerance of 5% in packet length, 50% on average packet Ton/Toff ratio

This Class B digital apparatus complies with Canadian ICES-003.

TCB

**GRANT OF EQUIPMENT
AUTHORIZATION**

TCB

Certification
Issued Under the Authority of the
Federal Communications Commission
By:

CETECOM ICT Services GmbH
Untertuerkheimer Strasse 6-10
D-66117 Saarbruecken,
Germany

Date of Grant: 07/24/2007
Application Dated: 07/24/2007

EnOcean GmbH
Kolpingring 18a
Oberhaching, 82041
Germany

Attention: Armin Anders , Director Product Marketing

NOT TRANSFERABLE

EQUIPMENT AUTHORIZATION is hereby issued to the named GRANTEE, and is VALID ONLY for the equipment identified hereon for use under the Commission's Rules and Regulations listed below.

FCC IDENTIFIER: SZV-PTM200C
Name of Grantee: EnOcean GmbH
Equipment Class: Part 15 Security/Remote Control Transmitter
Notes: Pushbutton Transmitter

<u>Grant Notes</u>	<u>FCC Rule Parts</u>	<u>Frequency Range (MHZ)</u>	<u>Output Watts</u>	<u>Frequency Tolerance</u>	<u>Emission Designator</u>
	15.231	315.0 - 315.0			



CETECOM ICT Services GmbH
 Untertürkheimer Strasse 6-10, D-66117 Saarbrücken, Germany



Conformity Assessment Body
Certification Body at Industry Canada

CERTIFICATE OF CONFORMITY

Certificate Holder:	EnOcean GmbH Kolpingring 18a 82041 Oberhaching Germany
Model Identification:	PTM200C
Description:	Pushbutton Transmitter
Equipment Category:	Remote Control Device
Standards and Specifications:	RSS210 Issue 7
OATS Facility:	Cetecom ICT Services GmbH Untertuerkheimer Str. 6 -10 66117 Saarbruecken Germany
OATS Facility ID:	3463A-1
IC Certification Number:	5713A-PTM200C
Frequency Range:	315 MHz
Emission Designator:	187KA1D
RF Output Rating:	59.8 dBµV/m @ 3m
Antenna Information:	External whip antenna
Cetecom Registration No:	2-4706/07

Certification of equipment means only that the equipment has met the requirements of the above noted specification. License applications, where applicable to use certified equipment, are acted on accordingly by the issuing office and will depend on the existing radio environment, service and location of operation. This certificate is issued on condition that the holder complies and will continue to comply with the requirements of the radio standards specifications and procedures issued by Industry Canada.

This certificate is issued on condition that the holder complies and will continue to comply with the requirements of the radio standards specifications and procedures issued by the Department.

The Bureau will record the details of all certifications in the Department's Radio List (REL). Certified equipment shall not be distributed, leased, sold, offered for sale in Canada before the details of this certification have been added to the REL. URL: <http://strategis.ic.gc.ca/sitt/reitel/search/newRadioSearch.do?language=eng>

2007-07-24
Date:

Gerald Schmidt

Signature:

Recognized by
IC
 CB ID: DE0001



3.6 Japanese Type Approval

PTM200C complies with the Japanese radio law. It carries the following marking on the back side label (MIC marking):

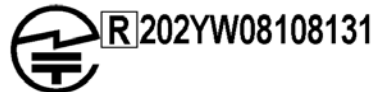

If the certification label cannot be recognized from outside (e.g. installation in a host) appropriate information must be referenced in the user manual.

CETECOM ICT Services GmbH Untertürkheimer Strasse 6-10, D-66117 Saarbrücken, Germany		
Conformity Assessment Body Recognized Certification Body for Japan		
認証書 TYPE- BASED CERTIFICATE		
特定無線設備の種類 Classification of specified radio equipment:	Article 2, Clause 1,Item 8 Specified low-power radio equipment Telemeter, Remote Control or data transmission (315MHz band)	
電波の形式、周波数 及び空中線電力 Type of emissions, frequency and antenna power	A1D 315 MHz(312-315.25 MHz) 0.2 mW	
CETECOM		
型式又は名称 Model Name:	PTM 200C	
製造者名 Manufacturer Name:	EnOcean GmbH	
認証番号 Certified Number:	202YW08108131	
認証をした年 月 日 Certified Date:	2009-01-07	
上記のとおり、電波法第 38 条の 24 第 1 項の規定に基づく認証を行ったものであることを証する。 This is to certify that the above-mentioned certification by type has been granted in accordance with the provisions of Article 38-24, Paragraph 1 of the Radio Law.		
		Cetecom ICT Services GmbH Lothar Spitzer Signature:
Recognized by The Ministry of Internal Affairs and Communications(MIC)		
CAB ID: 202		

4 DEVELOPMENT TOOLS

4.1 Evaluation Kit EVA 105C

EVA 100C is an evaluation kit to support a simple setting-up operation of the receiver side when the EnOcean transmitter device PTM 200C is evaluated. EVA 100C supports a quick evaluation of RCM 130C receiver operation modes and supports the fast development of applications.



Type	EnOcean Ordering Code	Scope of supply
EVA 105C	H3034-G105	<ul style="list-style-type: none"> ▪ Evaluation board EVA-PCB ▪ EnOcean radio devices STM 110C, PTM 200C, and RCM 130C ▪ CD with RS232 PC-link monitor software and detailed kit documentation ▪ Convenient equipment case ▪ 120V wall power supply

4.2 Field Intensity Meter EPM 100C

The EPM100C is a mobile field-intensity meter that helps the engineer to find the best installation positions for sensor and receiver. It can also be used to check disturbances in links to already installed equipment. The EPM100C displays the field intensity of received radio telegrams and interfering radio signals in the 315MHz range.

The simplest procedure for determining the best installation positions for the radio sensor/receiver:

- Person 1 operates the radio sensor and generates pushbutton radio telegrams.
- Person 2 checks the received field intensity on the meter display to find the optimal installation position.



Type	EnOcean Ordering Code
EPM 100C	S3034-J100

5 PATENT PROTECTION

PTM200C is protected by the following patents:

- US 6,747,573
- US 7,019,241
- Further patents pending