

MOS-17 installation guide



Echoflex Solutions, Inc.

1, 38924 Queens Way | Squamish
British Columbia | Canada | V8B 0K8
Toll Free: (888) 324-6359
sales@echoflexsolutions.com
www.echoflexsolutions.com

© 2011 - 2012 Echoflex Solutions, Inc.
Specifications subject to change
without notice.

Part # 8DC-5187 | Revision 1.4

Product Overview

The MOS-17C is a wireless, energy harvesting, ceiling mount, passive infrared (PIR) occupancy sensor. Used for indoor applications, the detector is optimized for ceiling heights of 8 - 10 feet.

The sensor broadcasts an EnOcean telegram when occupancy is detected and repeats transmissions with a minimum 100 second period between subsequent telegrams.

Powered by six solar cells, the MOS-17C can operate without battery backup for over 90 hours. An efficient power supply and tuned sensor circuitry allows the MOS-17C to provide immediate response to new occupancy states making it an ideal solution for auto-ON applications.

A walk-test feature allows installers to test and verify sensor operation on location without extra tools or software. False occupancy state tripping through pet movements or from other elements can be reduced with an on-board slide switch selecting a lower sensitivity setting.

This guide covers model numbers MOS-17 equipped with an 868MHz EnOcean radio and MOS-17C which are equipped with an EnOcean 315 MHz radios.

PIR Motion Detection

The PIR sensor is an optical sensor that detects motion by measuring the infrared heat given off by objects. The sensor is calibrated to detect the heat range of human body temperature.

The sensor has a lens that breaks the viewing angle of the sensor into zones that focus the light onto different sections of the sensing element. It is the movement of the infrared frequency moving in and out of a zone that defines motion.

The infrared light emitted is stronger

when people are closer to the sensor. Sensor range is measured in two planes; the ceiling height to 36" off the floor or table/desk height and the second, the linear distance from the sensor.

Sensor Range

The MOS sensor is offered with two different lens. There is a lens with a high sensor ray density pattern suitable for small motion detection however this

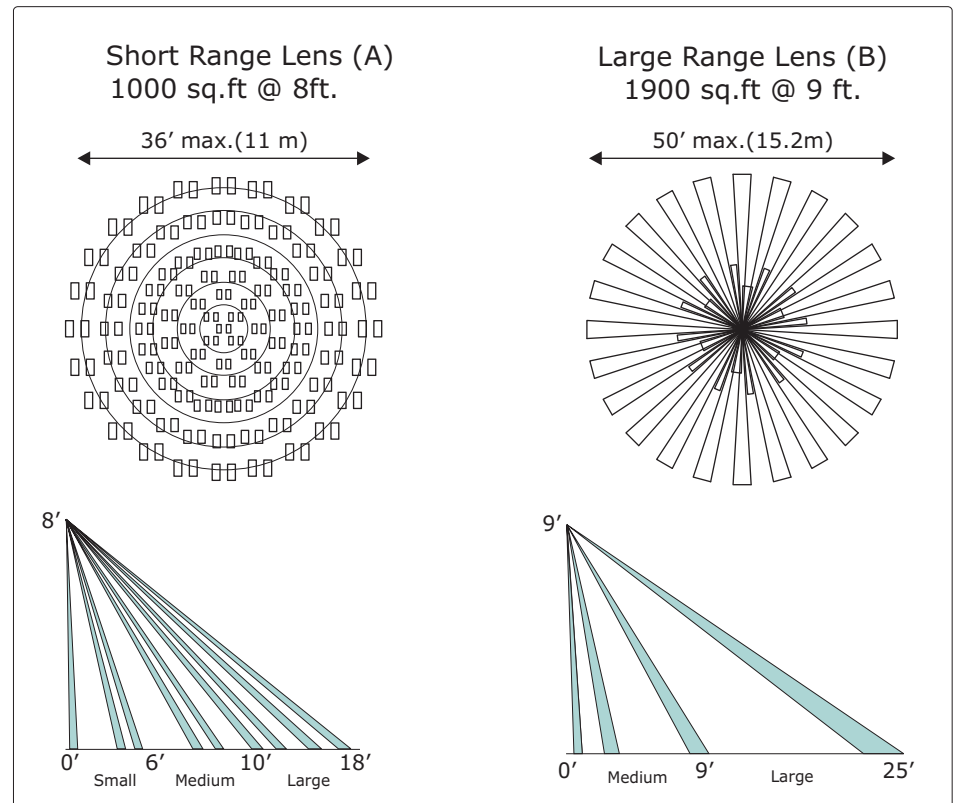

lens has shorter range. The second lens has a broader range but is less sensitive for small motion detection.

Sensor range can be separated into two fields of detection:

1. small motion - this is the area closest to the sensor and can detect small movement such as hand waving, picking up a coffee cup or answering the phone.

The small movement effective area will decrease as the ceiling height increases. Do not use the MOS-17 sensor for ceiling height applications where small movement detection is needed and the ceiling height is greater than 9 feet.

2. large motion - this is the area surrounding the small motion area extending to the sensor's range limit. The further from the sensor, the more diluted the sensor ray pattern becomes requiring larger body motion such as walking to trigger occupancy.

Sensor Location

There are three primary objectives when finding a suitable location for the sensor.

- 1) Placing the sensor for proper occupancy detection.
- 2) Placing the sensor so the receiver is within radio range.
- 3) Placing the sensor so it can harvest adequate light energy.

Occupancy Detection Zone

⇒ The sensor can not detect occupancy through solid objects including items placed by the tenant such as file cabinets and book shelves.

⇒ Do not locate the sensor near forced air vents as hot moving air will cause the sensor to false trigger. Leave at least 4' minimum between air vents and the sensor.

⇒ Incandescent lights can cause false trips when turning on.

⇒ Movement perpendicular to the sensors detection zones create stronger signals than movement directly towards or away from the sensor. Try to locate the sensor so movement is across the detection pattern.

⇒ Determine what kind of primary motion will trigger the sensor -

walking or hand movements. Hand waving and other small motion is only detectable at 6' (1.8m) maximum from the sensor location when mounted on a 8' ceiling with lens A. Walking and large motion is detectable up to 18' (6.1m) with lens A from the sensor on an 8' ceiling.

⇒ In offices and classrooms that measure 40' by 40' (12.2m by 12.2m) or less, one sensor is often sufficient. Centrally located, the sensor picks up the motion on the spaces peripheral

⇒ larger spaces will require some planning before positioning the sensors. Determine the type of traffic patterns, where occupants will be seated, and where doors are located. Locate the sensor so the detection patterns do not extend out doorways.

⇒ Hallway applications are mostly walking traffic parallel with the detection pattern so sensors should be mounted 30' (9.1m) maximum from each other as sensitivity will be decreased, see diagram.

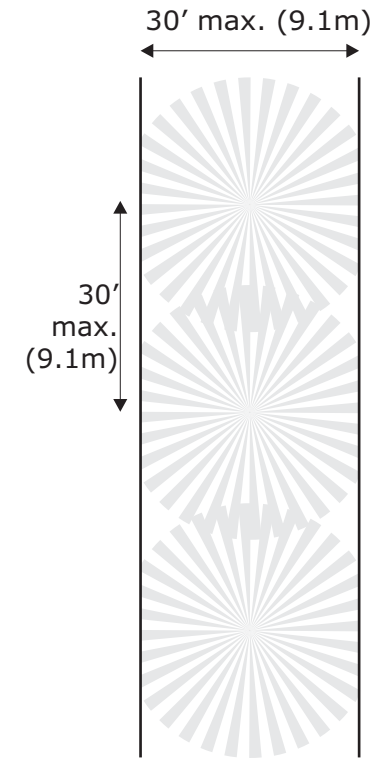

Hallway Application

⇒ Open office space or other open floor plan designs require additional sensors. Place the sensors in a grid adjusting for walls and furniture, see diagram.

Radio Range

The MOS-17 is a wireless transmitter intended to be used with Echoflex lighting control products. Locating the wireless transmitters to work with the lighting controller requires planning. Careful consideration should be made for locating the controllers and transmitters based on the construction materials in the space and possibility of tenant's furniture disrupting the transmissions. Fire doors, elevator shafts, stairwells, storage areas and any large metal products create radio shadows and will disrupt wireless transmissions.

Range Planning

On floor-plan drawings, draw 100 feet (30m) diameter circles to identify optimal transmitter and controller locations. Refer to the table for range considerations with other building materials. Use an EPM100C for on-site range testing and location suitability. The EPM100C provides the convenience of a hand-held device indicating signal strength from transmitters. The EPM100C will verify proper signal reception at your intended controller locations. For more information about range

planning, please refer to the range planning guide downloaded from "http://www.echoflexsolutions.com/files/downloads/ReliableRangePlanning_0308.pdf

| Material | Attenuation |
|---------------|-------------|
| Wood | 0 - 10% |
| Plaster | 0 - 10% |
| Glass | 0 - 10% |
| Brick | 5 - 35% |
| MDF | 5 - 35% |
| Ferroconcrete | 10 - 90% |
| Metal | 90 - 100% |
| Aluminum | 90 - 100% |

| Material | Range-typical |
|----------------|-------------------------------|
| Line of site: | 100' (30m) corridors |
| Line of site: | 330' (100m) open halls |
| Plasterboard: | 100' (30m) through 5 walls |
| Brick | 65' (20m) through 3 walls |
| Concrete: | 65' (20m) through 3 walls |
| FerroConcrete: | 33' (10m) |
| Ceiling: | 1 ceiling |

Signal Attenuation

The radio signal is attenuated by the materials that it passes through. Dense materials require more power to pass a radio signal consuming more of the signal strength and reducing the signal range.

Mounting the sensor

You can use double sided tape or wall anchors and screws to mount the MOS-17 sensor.

- 1) Using a fingernail, insert under the clear plastic lens at one of the relief tabs in the base plate and pull up.
- 2) You will need to repeat with at least two tabs until the lens pops free.
- 3) Hold the sensor in place and mark the two mounting holes with a pencil.
- 4) Install the wall anchors and screws per the package instructions leaving the screws loose.
- 5) Place the MOS-17 sensor so the screw heads go through the mounting holes and slide the sensor so the screw head is holding the base plate.
- 6) Tighten the screws, do not over tighten.

- 7) Replace the lens over the sensor aligning the link button hole with the button and press in place.

Sensitivity Setting

The MOS-17 sensor has a slide switch that the user can use to select max. or min. sensitivity levels. False occupancy states caused by other elements can be reduced by selecting the min. sensitivity level. The default setting is max. sensitivity.

To change the sensitivity setting:

- 1) Remove the clear plastic lens by inserting a fingernail under the lens at one of the relief tabs in the base plate and pull up.
- 2) Slide the switch over to the chosen setting.
- 3) Replace the lens over the sensor aligning the link button hole with the button and press in place.

Installing or replacing a battery

The MOS-17 sensor can have a CR2032 battery installed to backup the solar energy harvester. It is recommended

to install the battery for any application where the lights need to turn on based on the sensor output.

1) Remove the clear plastic lens by inserting a fingernail under the lens at one of the relief tabs in the base plate and pull up.

2) Using your fingers, remove the old battery by pulling the battery free from the holder. Do not use a screwdriver.

3) Insert the new battery and press in place with your finger.

4) Replace the lens over the sensor aligning the link button hole with the button and press in place.

Walk Test Feature

The walk-test feature allows the installer to test the placement of the sensor with the intended space usage patterns. An area where small hand movements shall trigger the sensor can be tested during installation to insure that the sensor is close enough to the area for this detection pattern.

NOTE: The MOS-17 sensor should be allowed to charge in a strong light source before using the walk-test feature.

1) Press the link button to start the walk test.

2) An on-board led will blink when

motion is detected. The led should be clearly visible as the walk test is performed.

3) The walk test will time out after approximately 60 seconds and resume normal operation.

Linking the MOS-17C

Linking the MOS-17C to a receiver creates the communication link between

the sensor and a controller.

1) Place the receiver in LINK mode, consult the manufactures instructions if necessary.

2) Press the LINK button on the MOS-17C sensor. The sensor will transmit the TEACH telegram to the receiver.

3) Exit LINK mode.

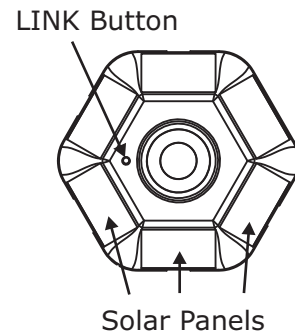

Layout Hints



⇒ Avoid transmitting down a length of wall to reduce signal reflection.

⇒ Avoid transmissions that must penetrate walls at acute angles. This increases the wall material the telegram must pass through, greatly reducing the signal power.

⇒ Avoid large obstructions. Place receivers in alternate locations to avoid the radio shadow or use repeaters to go around the obstacle.

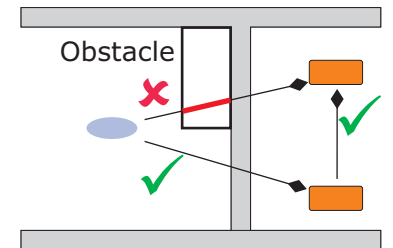
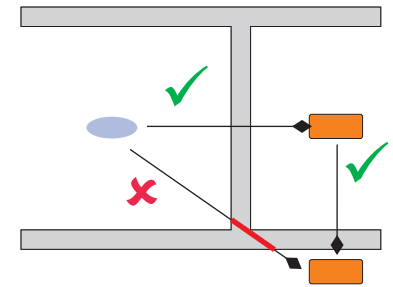
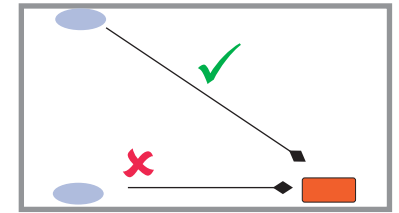
⇒ Do not locate receivers close to other high frequency transmitters. Leave at least 2' between the receiver and any other source of interference including, computers, video equipment, Wi-Fi/LAN routers, GSM modems and monitors. Transmitters are not affected by these sources of interference.



-  Receiver and Repeater
-  Transmission
-  Transmitter

EnOcean Equipment Profiles

EEP: A5-07-01 Occupancy Sensor - PIR ON, PIR OFF

Technical Specifications

| | |
|--|--|
| Power Supply | Solar cell, optional battery (CR2032) backup, |
| Operational Light Level | 30 lux (3 foot candles) minimum |
| Charging Period | 6 hours full charge at 200 lux (19 foot candles) |
| Initial Operation | 60 seconds in 30 lux (3 foot candles) |
| Full Charge Operation | minimum 60 hours in 0 lux after 6 hours @ 200 lux charging period |
| Telegram Transmission | on motion or on heartbeat period |
| Telegram Heartbeat Period | 110 seconds ± 20 seconds |
| Communications | |
| Radio Type | 315 MHz or 868MHz EnOcean radio |
| NOTE: The radio is protected by a sealed screw. Breaking this seal will void the warranty | |
| Antenna | Integrated whip |
| Transmission Range | 30m (100 ft.) - commercial office space |
| Inputs | LINK button for assignment to receiver |
| Outputs | Walk-Test LED |

Mechanical Specifications

| | |
|-------------------------------|--|
| Optimal Operating Temperature | 32°F to 86°F (0°C to 30°C) |
| Relative Humidity | 5% to 95% RH (non-condensing) |
| Weight | 3.7 oz. (104 gms.) |
| Dimensions | 4.8" diameter, 1.5" height (122 mm x 38 mm) |
| Mounting | mount with screws or tape (Velcro®), not supplied |

Agency Listing and Compliance

| | |
|-----------------|--|
| Radio Frequency | FCC Part 15.231 - Remote Control Transmitter 315MHz radio equipped- Contains FCC ID: XMG-STM112C 868MHz radio equipped- Contains FCC ID: SZV-STM110 The enclosed device complies with Part 15 of the FCC Rules. Operation is subject to the following two conditions: (i.) this device may not cause harmful interference and (ii.) this device must accept any interference received, including interference that may cause undesired operation. IC RSS-210 315MHz radio equipped- Contains IC: 7256A-STM112C 868MHz radio equipped- Contains IC: 5713A-STM110 |
|-----------------|--|