

ERDRC-C or ERDRC-O installation guide



Echoflex Solutions, Inc.

1, 38924 Queens Way | Squamish | British Columbia
Canada V8B 0K8

Toll Free: (888) 324-6359
sales@echoflexsolutions.com |
www.echoflexsolutions.com

© 2010 Echoflex Solutions, Inc.
Specifications subject to change without notice.
Part # 8DC-5012 | Revision 1.2

Product Overview

Echoflex's SmartSpace Controllers use wireless technology to monitor the room's environment eliminating much of the wiring normally required for this level of distributed control. This translates into quick installations with less disruption to occupants allowing facilities to accelerate retrofit schedules and start saving money sooner. The SmartSpace Controllers have Echoflex's Smart Click technology which allows installers and facility operators to manage configuration settings without any tools reducing call-backs and installation expense. Using just a wireless wall switch, the facility maintenance engineer can adjust setting on the installed controllers eliminating a service call to an electrician.

This guide covers model numbers ERDRC-OC/ERDRC-CC which are equipped with an EnOcean 315 MHz radios and ERDRC-O/ERDRC-C controllers equipped with 868MHz EnOcean radios.

The package includes the ERDRC controller and installation guide.

Planning the Installation

The ERDRC controller is intended to be used with switches, sensors and actuators enabled with EnOcean PTM or STM transmitters. Locating the wireless transmitters to work with the installed ERDRC controller requires planning. Careful consideration should be made for locating the controllers based on the construction materials in the space and possibility of tenant's furniture disrupting the transmissions. Fire doors, elevator shafts or any large metal products will disrupt wireless transmissions.

One method of planning the installation is to draw 30m (100 feet) diameter circles on floor-plan drawings to identify optimal transmitter and controller locations. Refer to the table below for range considerations with common materials.

Material	Signal Range-typical
Line of site:	100' (30m) corridors 330' (100m) open halls
Plasterboard:	100' (30m), through 5 walls
Brick, Aerated Concrete:	66' (20m), 3 walls
FerroConcrete, Ceiling:	33' (10m), 1 ceiling

Important Safety Instructions

WARNING:

ELECTRICAL SHOCK HAZARD

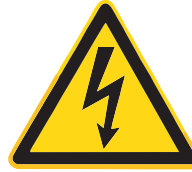

THE ERDRC USES HIGH VOLTAGE AND SHOULD ONLY BE INSTALLED BY A QUALIFIED INSTALLER OR ELECTRICIAN. FOLLOW ALL APPLICABLE

ELECTRICAL CODES IN THE COUNTRY OF INSTALLATION.

Installing the ERDRC

Review these instructions completely before installing the ERDRC controller.

- 1) Locate the circuit breaker panel and turn off the power to the circuit.
- 2) Remove all face plates and other hardware from the junction box so you can access the high voltage wires.
- 3) The ERDRC is mounted to the exterior of the junction box or panel with the ½" threaded nipple.
- 3) Refer to the wiring diagram to connect the ERDRC to the line power, neutral and load wires. Use wire nuts on all connections and cap any bare wires.
- 4) Replace the junction box faceplate.
- 5) Connect the low voltage occupancy sensor power and signal wires to the occupancy sensor. Refer to the wiring chart below for wire descriptions.
- 6) (For ERDRC-C models only) Connect the low voltage dimming wires to the dimming ballast input. Refer to the wiring chart below for wire descriptions.
- 7) Restore power to the circuit.
- 8) Refer to the section in this guide titled **LEARN Button** to assign a switch or sensor to the controller. Alternatively, refer to the Smart Click instructions on page 4 for assigning switches and sensors remotely.

An alternative method is to use a hand held EPM100 for on-site range testing and location suitability. The EPM100 provides the convenience of a hand-held device indicating signal strength from transmitters. The EPM100 will verify proper signal reception at your intended controller locations.

For more information about range planning, please refer to the range planning guide downloaded from "http://www.echoflexsolutions.com/files/downloads/Reliable Range Planning_0308.pdf"

Preparing to Install

The ERDRC is mounted to an electrical junction box or panel with a ½" threaded nipple. The antenna for the controller is embedded in the housing requiring the ERDRC to be mounted on the outside of the junction box either directly at the electrical load or before the load in the circuit.

You will require hand tools to gain access to the junction box and remove any cover plates or other hardware. A pin or pen is needed for pressing the controller buttons when linking the wireless switches.

Use with an Occupancy Sensor

The ERDRC can provide 24VDC to power an occupancy sensor and has a signal input line for sensor status. The input is active high so when 24V is active on the yellow signal line, the controller will respond to the occupied state. There is a time-out feature in the controller that can be configured to hold an occupancy state before entering the unoccupied state. Refer to the Smart Click section and the back of this guide to configure the time-out feature.

Use with a Dimming Ballast (ERDRC-C)

The ERDRC-C has a 0-10V dimming output for connections to dimming ballast fixtures. The controller will modulate the output based on a light level setpoint, maximum dimming output and minimum dimming output configured in the Smart Click menu.

Use with a wired wall switch

If the circuit will have an additional manual switch, wire the ERDRC in series before the manual switch.

Wiring Instructions

Power to the controller is connected between the White (Neutral) and the Black (120V). Optionally, based on model number, commercial voltages are applied between the White (Neutral) and the Brown(277V) or Yellow(347V). (see wiring diagram).

Use only approved wire. Cap off all unused wires.

ERDRC-C Wiring Diagram using 120V line power

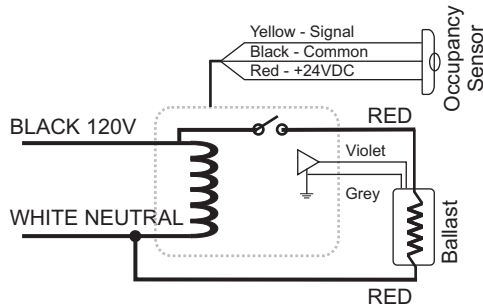

ERDRC-C Wiring Diagram using 277V or 347V line power

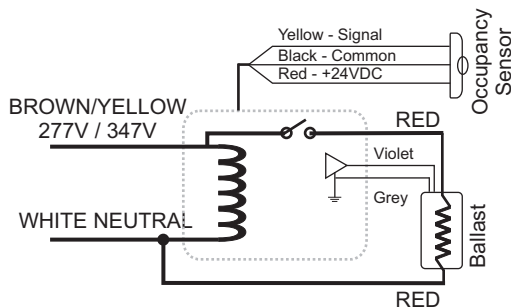

Line Voltage Connections

Description	Color	Specification
LOAD x 2	Red	14AWG, 600V
Neutral	White	18AWG
120VAC	Black	18AWG
277VAC*	Brown	18AWG
347VAC*	Yellow	18AWG

Low Voltage Occupancy Sensor Connections

+24VDC	Red	22AWG
-Common	Black	22AWG
Occ.Signal	Yellow	22AWG

Low Voltage Dimming Ballast Connections

Ballast Common*	Grey	22AWG
0-10V Dimming*	Violet	22AWG

*not used in all models

Learn and Clear Buttons

LEARN button – The LEARN button is used to link a switch or switch to the ERDRC controller.

1. Insert a small pin or pen into the LEARN hole depressing the button for a half second. In link mode the LEARN led will stay ON and the POWER led will toggle every 2 seconds.

2. Using the switch that you want to link to the controller, press the wall switch three times or press the sensors TEACH (or LINK) button. The POWER led will remain lit for 4 seconds while it links the new device. It will resume toggling allowing you to link another device up to a total of 30 devices. Linking a switch or sensor that is already linked to a controller, will remove or un-link it from the controller.

3. To exit link mode, depress the LEARN button on the ERDRC controller again for a half second. Link mode will time out after no activity in 30 seconds.

CLEAR button – The CLEAR button erases all switches linked to the ERDRC controller and resets the controller to factory default settings.

Insert a small pin or pen into the CLEAR hole depressing the button for 5 seconds. The LEARN led will flash ON for 1 second and then OFF to complete the step.

Diagnostic LED'S

Use the table below to decode what type devices have been linked and current operating mode of a controller.

Description	LEARN	POWER
LINK mode	ON	Toggle 2 sec.
Storing ID	ON	ON 4 sec.
Clearing ID	ON	OFF 4 sec.
CLEAR mode	ON 1 sec.	n/a

Normal operation, see below

In normal mode: Learn led is OFF

nothing linked Power led ON, relay closed (factory default)

Switch: Power led-one long blink followed by short blinks counting switches

Wireless Occ.sensor: Power led-two long blinks followed by short blinks counting sensors learned

Wired Occ.Sensor: Power led-two long blinks

Wireless Photo Sensor: Power led-three long blinks followed by short blinks counting sensors learned

Smart Click Instructions for ERDRC

Configuring the ERDRC controller requires that at least one wireless PTM wall switch is linked to the controller.

Linking the first switch

⇒ With the ERDRC controller in the factory default state, click the PTM switch ON three times, OFF three times and ON three times quickly.

Using this method of linking a switch will only work on the first PTM switch. Use Smart Click to link additional switches or to configure the controller parameters.

Using Smart Click to Configure the ERDRC

It is important to have feedback from the ERDRC controller during configuration. Insure the lighting circuit is active and that you can turn the lights on and off with the wireless switch.

- ⇒ Using a linked switch (see above), turn the light OFF.
- ⇒ Click and hold the switch OFF for 10 seconds. The light will blink once and then turn on. If the switch is linked to more than 1 ERDRC controller you will have to click the ON side of the switch until the controller you wish to configure is selected indicated by the light turning ON.
- ⇒ Press ON for 5 seconds. The light will begin blinking once.

Linking an additional switch or sensor

- ⇒ With the light blinking once, press ON for 3 seconds. The light will begin blinking ON/OFF every second.
- ⇒ Add additional PTM switches by clicking ON 3 times quickly. Add sensors by pressing the TEACH button on the sensor.
- ⇒ To continue with configuration, press the switch ON for 3 seconds, the light will resume blinking once. To exit Smart Click press OFF for 5 seconds.

Clear switches or sensors (restore factory defaults)

- ⇒ Click the switch ON or OFF until the light is blinking twice.
- ⇒ Click the switch ON 5 times to clear the switch, click ON 5 times again to clear ALL switches and sensors and reset the ERDRC to factory defaults.

⇒ Press OFF for 5 seconds to complete clearing.

Repeater Function - repeats any telegram within range. EnOcean telegrams can only be repeated once.

- ⇒ Click the switch ON or OFF until the light is blinking three times.
- ⇒ Press ON for 3 seconds. If the repeater function is enabled the light will turn ON, if disabled the light will be OFF.
- ⇒ Click ON to activate this function, OFF to deactivate.
- ⇒ To continue with configuration, press ON for 3 seconds, the light will resume blinking three times. To exit Smart Click press OFF for 5 seconds.

Status Telegram - the ER1C-BFC can broadcast a status telegram per EEP: 07-11-01. The telegram will broadcast every 100 seconds. Refer to the table on page 5 for a detailed explanation of the telegram.

- ⇒ Click the switch ON or OFF until the light is blinking four times
- ⇒ Press ON for 3 seconds. If the status telegram function is enabled the light will turn ON, if disabled the light will be OFF
- ⇒ Click ON to activate this function, OFF to deactivate
- ⇒ To continue with configuration, press ON for 3 seconds, the light will resume blinking four times. To exit Smart Click press OFF for 5 seconds

Timeouts - the ERDRC can be configured to wait a period of time after an ON event from a PTM switch or occupancy sensor before turning the load OFF (auto-off).

- ⇒ Click the switch ON or OFF until the light is blinking five times.
- ⇒ Press ON for 3 seconds. The light will turn OFF and then ON per the table settings below.

Light	Switch Timer	Occ.Sensor Timer
ON	no auto-off	0 sec.
1 Blink	30 min.	5 min.
2 Blinks	60 min.	10 min.
3 Blinks	95 min.	15 min.
4 Blinks	120 min.	20 min.
5 Blinks	150 min.	25 min.

- ⇒ Click ON move down the table, OFF to move up.
- ⇒ To continue with configuration, press ON for 3 seconds, the light will resume blinking five times. To exit SmartClick press OFF for 5 seconds.

Auto-ON Function - use with an occupancy sensor to turn lights ON automatically when motion is detected.

- ⇒ Click the switch ON or OFF until the light is blinking six times.
- ⇒ Press ON for 3 seconds. If the auto-on function is enabled the light will turn ON, if disabled the light will be OFF
- ⇒ Click ON to activate this function, OFF to deactivate
- ⇒ To continue with configuration, press ON for 3 seconds, the light will resume blinking six times. To exit SmartClick press OFF for 5 seconds.

Dimming Ballast -used only for the ERDRC-C. Enable or disable the dimming ballast output.

- ⇒ Click the switch ON or OFF until the light is blinking seven times.
- ⇒ Press ON for 3 seconds. If the dimming ballast function is enabled the light will turn ON, if disabled the light will be OFF.
- ⇒ Click ON to activate this function, OFF to deactivate.
- ⇒ To continue with configuration, press ON for 3 seconds, the light will resume blinking six times. To exit SmartClick press OFF for 5 seconds.

Light Level Setpoint - use with a photo sensor(light sensor) to automatically turn lights on or off depending on ambient light levels.

- ⇒ Click the switch ON or OFF until the light is blinking eight times.
- ⇒ Press ON for 3 seconds. Default setting is 60% of the light sensors full range. Adjust the light level to the brightness level when the light should trigger OFF, see diagram below. There are 5 steps from 20% to 100% - the light will blink the step count.

In the diagram, the red line indicates the light off

event, the green line indicates the light on event. The light on event is 85% of the light off setpoint. For example: 85% of 60 = 50% of the light sensors full range.

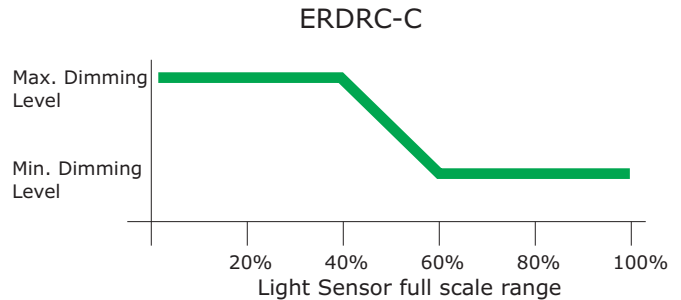
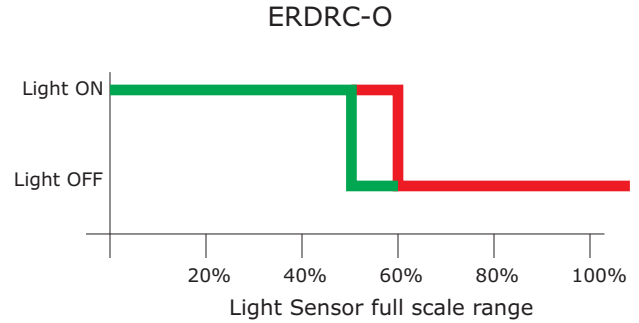

- ⇒ Click on to increase the setpoint, off to decrease the setpoint.
- ⇒ To continue with configuration, press ON for 3 seconds, the light will resume blinking six times. To exit SmartClick press OFF for 5 seconds.

Maximum Dimming Output - the maximum output level corresponds to the highest light level output when the lights are at the brightest or full ON.

- ⇒ Click the switch ON or OFF until the light is blinking nine times.
- ⇒ Press ON for 3 seconds. Default setting is 100%. Adjust the max. light level to the brightness level desired by clicking ON to increase and OFF to decrease in 2% units.

- ⇒ To continue with configuration, press ON for 3 seconds, the light will resume blinking six times. To exit SmartClick press OFF for 5 seconds.

Broadcast Occupancy Telegram - the maximum output level corresponds to the highest light level output when the lights are at the brightest or full ON.

- ⇒ Click the switch ON or OFF until the light is blinking ten times.
- ⇒ Press ON for 3 seconds. If the broadcast

occupancy function is enabled the light will turn ON, if disabled the light will be OFF.

- ⇒ Click ON to activate this function, OFF to deactivate.
- ⇒ To continue with configuration, press ON for 3 seconds, the light will resume blinking six times. To exit SmartClick press OFF for 5 seconds.

Default Settings for ERDRC

Repeater	disabled
Status	disabled
Time-out(auto-off)	disabled
Dimming output	enabled
Auto-ON	enabled
Light Level Setpoint	60%
Maximum Light Level	100%

Status Feedback Telegram

EEP:07-11-01

DB_3 Illumination

0 ... 510lx, linear n=0...255

DB_2 Illumination Set Point

Min. ... Max., linear n=0...255

DB_1: Dimming Output

Level Min. ... Max., linear n=0...255

DB_0.BIT_7: Repeater

0b0 disabled, 0b1 enabled

DB_0.BIT_6: Power Relay Timer

0b0 disabled 0b1 enabled

DB_0.BIT_5: Daylight Harvesting

0b0 disabled 0b1 enabled

DB_0.BIT_4: Dimming

0b0 switching load 0b1 dimming load

DB_0.BIT_3: Learn button

0b0 Teach-in telegram 0b1 Data telegram

DB_0.BIT_2: Magnet Contact

0b0 open 0b1 closed

DB_0.BIT_1: Occupancy

0b0 unoccupied 0b1 occupied

DB_0.BIT_0: Power Relay

0b0 off 0b1 on

EnOcean Equipment Profiles - remote devices supported

EEP: 05-02-02	Light - US/Canada application
EEP: 07-06-02	Light Sensor [range 0 - 1024 lux]
EEP: 07-07-01	Occupancy Sensor

Hardware Specifications

Power Supply	120/277 VAC or 120/347 VAC, 60Hz
Power Consumption	6.5 W max. full load
Power Output	24 VDC @ 125 mA
Input	Optically Isolated 24VAC/DC input
Outputs	N.O. Relay rating 15A@347 VAC or 20A@120 or 277 VAC 0-10VDC dimming ballast output
Inputs	LEARN and CLEAR buttons for sensor assignment
Communications	315 MHz or 868 MHz EnOcean radio with whip antenna

Mechanical Specifications

Operating Temperature	14 F to 113 F (-10 C to 45 C)
Relative Humidity	5% to 95% RH (non-condensing)
Weight	13.5 oz. (385 gms.)
Dimensions	3.5"x1.9"x1.9"(88 x48 x 48 mm)
Mounting	½" nipple

Agency Listing and Compliance

Safety	ETL Recognized Component 3188207 Conforms to UL Standard 508 Certified to CAN/CSA Std. C22.2 No.14 UL 2043 Plenum rated
Radio Frequency	FCC Part 15.231-Remote Transmitter IC RSS-210