

Echoflex Installation Guide

Elaho Dual Tech Wall-mount Occupancy Sensor

Overview

The Elaho Dual Tech Wall-mount Occupancy Sensor uses passive infrared (PIR) technology and acoustic detection to provide reliable occupancy and vacancy sensing for lighting control.

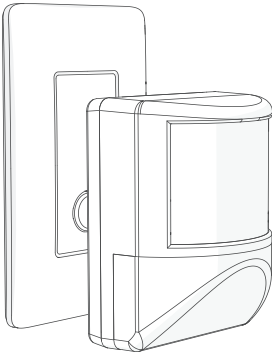

The wall-mount unit offers up to 140 degree field of detection with optimized lens options to accommodate wide or narrow angle spaces.

Wall-mount - Wide Angle Lens - coverage

- 18.3 m (60 ft) at mounting height of 2.1-3 m (7-10 ft)
- 140 degree field of detection

Wall-mount - Narrow Angle Lens - coverage

- 4.9 x 22.9 m (16 x 75 ft) at mounting height of 1.8-2.1 m (6-7 ft)
- 40 degree field of detection

See [Sensor Coverage on page 11](#).

Custom Configuration

This document guides you through the installation and local DIP switch setup of the sensor. For more detailed information about custom configuration options available using ElahoAccess, see the ElahoAccess Mobile App integrated help system.



Note: To use the configuration settings applied using ElahoAccess, DIP switch 2 must be enabled. See [DIP Switches on page 7](#).



Echoflex Installation Guide

Dual Tech Wall-mount Occupancy Sensor

Prepare for Installation

Elaho Dual Tech Wall-mount Occupancy Sensors ship with electronics, a decorator style wall plate, and a termination kit. The sensor may be installed into an industry standard back box (provided by others) or surface mounted back box (sold separately and available from Echoflex).

Compliance

- cULus Listed
- CE compliant

For use with Echoflex Elaho Control Systems, powered by an Elaho station power supply.

Environment

Ambient

For indoor, commercial controls use only. Operating temperature 0-40°C (32-104°F), humidity maximum 90% (non-condensing).

Location

Echoflex recommends paying special attention to the installation environment:

- When operating in PIR only modes, the sensor must have an unobstructed view of the room. Do not mount behind or near tall cabinets, shelves, hanging light fixtures, etc.
- Do not install the sensor within eight feet from an HVAC airflow duct/vent.
- Install the sensor where it cannot easily sense movement in areas outside of the intended space, such as hallways, glass partitions, or adjacent rooms.



Note: *In areas of increased noise activity, enabling PIR only mode may allow for better occupancy detection results. See [DIP Switches on page 7](#).*

Echoflex Installation Guide

Dual Tech Wall-mount Occupancy Sensor

Wire Specification

The Dual Tech Wall-mount Occupancy Sensor connects to the EchoConnect communication bus. EchoConnect is a bi-directional protocol that uses one pair of wires (data+ and data-) for both data and power. Echoflex recommends using Belden 8471 Class 2 wire (or approved equal - see the Echoflex cable cross database echoflexsolutions.com/files/Elaho_Data_Cable_Wire_Spec for equal alternatives). The total combined length of an EchoConnect wire run using Belden 8471 may not exceed 500 m (1,640 ft), with a maximum distance of 400 m (1,312 ft) between any two devices.



Note: *All control wiring should be installed and terminated by a qualified installer and should follow standard wiring installation practices. Leave approximately 25.4 cm (10 in) of wiring in the back box for connection and to allow slack for future service needs.*



Note: *Echoflex requires that all stations and devices be grounded for ESD protection. Pull an additional 2.5 mm² (14 AWG) wire for grounding when control wires are not installed in grounded metal conduit.*



Note: *When using Category 5 (or equivalent) cable on the EchoConnect communication bus, please note the following:*

- *Cat5 wiring must be terminated using EchoConnect Cat5 Termination Kit and must be installed using a bus topology. Refer to the installation guide that is provided with the Cat5 Termination Kit (8186A1207) for information to terminate Cat5 wiring.*
 - *Not all topologies are supported using Cat5; careful planning is required to ensure the proper termination kits are available and the wire is pulled appropriately.*
-

Supplies

The following supplies are provided with the sensor:

- mounting bracket with pre-routed EchoConnect and ground wires
- 2 each mounting screws, 6-32 x 3/4" and 6-32 x 1 3/4"
- WAGO connectors (wire termination connectors)
- decorator style wall plate

Echoflex Installation Guide

Dual Tech Wall-mount Occupancy Sensor

Installation



Note: NEC Class 2 product to be wired in accordance to NEC Article 725 and local jurisdiction requirements.

The wall-mount sensor is provided with a mounting bracket with pre-routed wires that can be mounted to a back box. Follow the detailed instructions for installation.

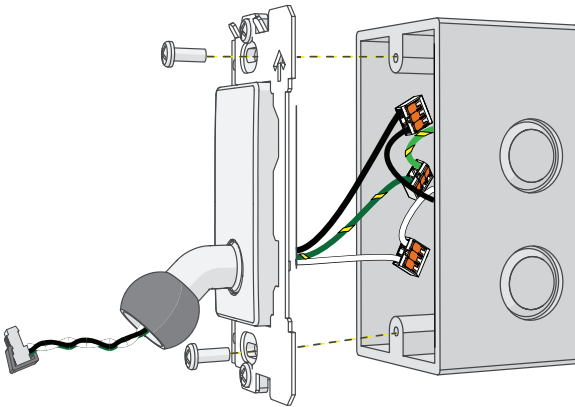

1. Pull the Belden 8471 (or equivalent) and one 2.5 mm² (14 AWG) ground wire to the mounting location (back box or surface mounted back box) and strip each wire 11 mm (7/16 in).
2. Connect the EchoConnect pigtail wires from the mounting bracket to the installed wall wires.
 - a. Connect the data- (typically black) EchoConnect wire from mounting bracket to the incoming data- (typically black) wire using a WAGO wire termination connector (provided).
 - b. Repeat the above steps for the data+ (typically white) EchoConnect wire and for the ESD ground wire, using a new WAGO connector for each termination type.
3. Orient the mounting plate to the back box with the directional arrows in the upright position and secure it in place using the screws provided.

Echoflex Installation Guide

Dual Tech Wall-mount Occupancy Sensor

4. Install the wall plate to the mounting plate.

- Align the top of the wall plate to the mounting plate, angling the bottom slightly.
- Hook the top of the wall plate to the tabs located on the mounting plate.
- Swing the wall plate down, ensuring the neck of the sensor extension and wires feed through the opening, until the magnets engage.
- If the wall plate does not fully attach, wiggle the bottom of the plate until all of the magnets are seated properly.

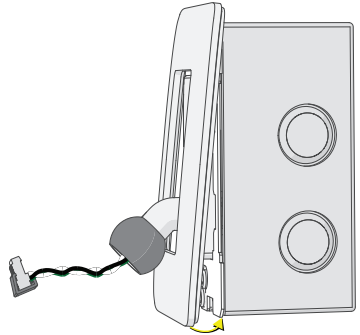

5. Attach the sensor head.

- Slide the removable cover off the sensor head.
- Route the three-position connector with wiring pigtail through the sensor head.
- Loosen the set screw on the sensor retaining ring.
- Slide the sensor onto the ball socket, and then tighten the set screw until secure.

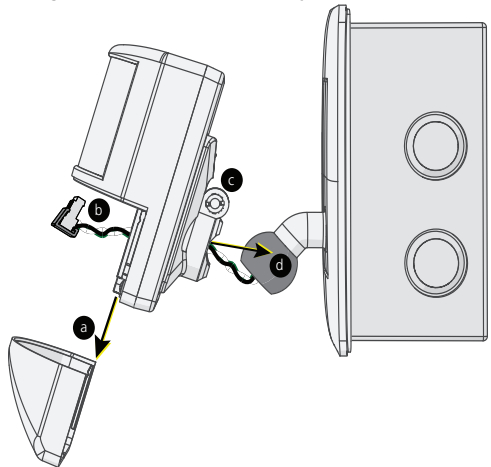

6. Connect the three-position connector to the receptacle on the sensor electronics.

Echoflex Installation Guide

Dual Tech Wall-mount Occupancy Sensor

Settings

The Elaho Dual Tech Wall-mount Occupancy Sensor participates in an Elaho control system using the configured Space and Address, which are selectable using the rotary switches on the sensor electronics located behind the removable cover.

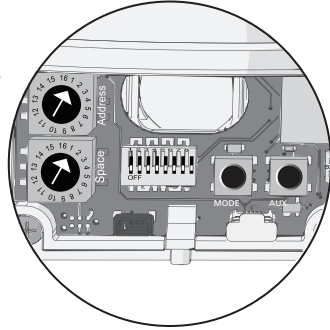

DIP switches and the **[MODE]** button, also located on the sensor electronics, set the sensor functionality and the occupancy detection action when set to Basic configuration mode. See [Configuration on page 8](#).



Note: When the sensor is placed into Custom configuration mode, DIP switch 2 set to On, all other DIP switch and Mode button settings are ignored.

Set Space and Address

Two rotary switches on the controller provide for assignment of the sensor Space and Address. By default, these switches are set to Space 1, Address 1. Commands are shared by all devices within a given space.

1. Set the Space rotary switch to the desired number (1 through 16) for the space you want the sensor to control.
2. Set the Address rotary switch to desired address (1 through 16) for the sensor identification in the selected space.



Note: Do not duplicate a device Address within the same Space.

Echoflex Installation Guide

Dual Tech Wall-mount Occupancy Sensor

DIP Switches

DIP switches on the sensor electronics provide for additional configuration options including Use Custom Config, Vacancy Timeout, Enable/Disable detection LEDs, PIR Only, and the ability to restore the sensor to its factory defaults.

Switch #	Use
1	Unused
2	Enable/Disable Custom Config Mode <ul style="list-style-type: none">• When "Custom Config" is set to Off (also known as Basic configuration mode), local DIP switch settings for Vacancy Timeout, Enable PIR LED, and dual technology features are used. Sensor actions can be adjusted using the program [MODE] button. This is the default setting. See Configuration on page 8.• When "Custom Config" is set to On, all other local DIP switch settings are ignored. Instead, the settings made by the EchoAccess Mobile App are used.
3 and 4	Vacancy Timeout <ul style="list-style-type: none">• 5 min = Switches 3 and 4 are Off• 15 min = Switch 3 is Off and Switch 4 is On (default)• 30 min = Switch 3 is On and Switch 4 is Off• Auto = Both switches are On
5	Detection LEDs <ul style="list-style-type: none">• When set to On (default), the occupancy detection LEDs illuminate when movement is detected.• When set to Off, the occupancy detection LEDs are disabled unless the unit is in Walk Test mode.
6	PIR Only Mode <ul style="list-style-type: none">• When set to On, acoustic detection technology is disabled for the sensor.• When set to Off (default), both PIR and acoustic detection technologies are used by the sensor.
7	Unused
8	Restore to Defaults at boot <ul style="list-style-type: none">• When set to On and power is cycled to the sensor, the unit restores to its factory default settings.• Off is the default setting.

Echoflex Installation Guide

Dual Tech Wall-mount Occupancy Sensor

Power Up

All EchoConnect terminations in the system must be made before applying power to the system and sensor. When the sensor is powered up, the PIR and acoustic detection LEDs illuminate for one minute for calibration and warm-up, and then return to normal operation according to the configuration.

Both the PIR and acoustic detection features of the sensor will automatically adjust sensitivity threshold to eliminate nuisance tripping. During this time, sensor configuration is not allowed and no events are triggered.

Operation

Dual Technology

When both PIR and acoustic detection are used, the following logic is used:

- When the space is vacant, PIR detection and manual control can switch the state to occupied.
- When the space is occupied, PIR, acoustic detection, and manual control can reset the vacancy timeout.
- When occupancy in the space has only been triggered by acoustic detection for 60 minutes, acoustic detection is disabled until the next PIR detection event.

PIR (only) Detection

When acoustic detection is disabled (DIP switch 6 set to On), the following logic is used:

- When the space is vacant, PIR detection and manual control can switch the state to occupied.
- When the space is occupied, PIR detection and manual control can reset the vacancy timeout.

Configuration

Program Mode

Program mode allows for local configuration of a sensor that is set for Basic configuration mode (DIP switch 2 set to Off). All basic configuration is set locally on the sensor using the other available DIP switches, the **[MODE]** button and associated amber Mode LED, and the Auxiliary "A" button and associated blue Auxiliary LED.

Echoflex Installation Guide

Dual Tech Wall-mount Occupancy Sensor

The **[MODE]** and **[AUX]** buttons and LEDs are located on the sensor electronics, accessible with the cover removed. See [Program Mode on the previous page](#) and [Vacancy Timeout below](#) for local Elaho program mode configuration instructions.

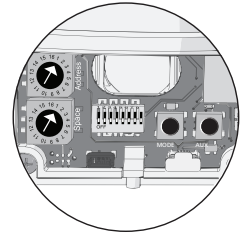

Preset

Use the **[MODE]** and **[AUX]** buttons to program the preset that is activated with an occupancy detected state change. By default, this is Preset 1. When vacancy is detected, the default action event is Off.

Follow these steps to configure the preset for your sensor:

1. Press and hold the **[MODE]** button for three seconds to enter "Program Mode." The amber LED lights to indicate the sensor is in Program Mode and the blue LED flashes to indicate the preset number controlled by the occupancy action. By default, this is Preset 1, therefore the blue LED will flash one time.
2. Press and release the **[AUX]** button the number of times that corresponds to the preset that you want to use. For example, press the **[AUX]** button eight times to set Preset 8. The blue LED flashes the number of the preset used.
3. Press and release the **[MODE]** button to save the current setting.
4. Reinstall the sensor cover.

Vacancy Timeout

Vacancy timeout is the amount of time the sensor waits to take action after no movement is detected. By default, vacancy timeout is set to 15 minutes (indicated by DIP switch 3 set to Off and 4 set to On; see [DIP Switches on page 7](#)). When the vacancy timeout ends, the grace period begins.

When the sensor detects vacancy, the vacancy timeout period begins. If the sensor does not detect occupancy again during the vacancy timeout period, the lights turn off and a 30 second grace period begins.

Grace Period

The sensor features a 30 second grace period after a vacancy timeout occurs. During this grace period, if the sensor detects occupancy, it will turn on or restore the previous lighting condition.

Auto Vacancy Timeout

The "Auto" vacancy timeout setting varies the vacancy timeout between 5 and 30 minutes depending on how often it identifies an occupancy trigger after a vacancy timeout occurs (during the grace period).

Echoflex Installation Guide

Dual Tech Wall-mount Occupancy Sensor

Walk Test

The sensor offers a Walk Test mode, which shortens the vacancy timer to ten seconds and allows for simple and quick verification of the sensor's coverage and range in the installed space.

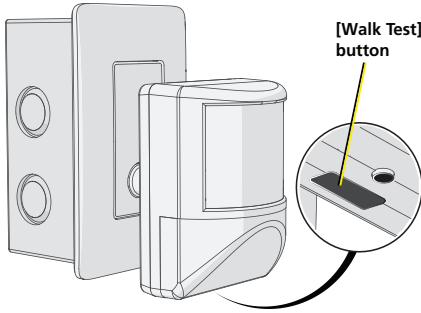

1. Prepare the site for configuration.
 - a. Make certain the sensor and lighting loads are powered and connected for control by the Elaho control system.
 - b. You will need direct access to the sensor in order to place it into Walk Test mode.
2. Press the **[Walk Test]** button on the bottom of the sensor to enable the Walk Test feature. A green LED will flash, indicating Walk Test is enabled and the vacancy timer will be shortened to ten seconds.
3. Move throughout the space including corners and areas that may be obscured from line of sight to the sensor. Each time the sensor detects movement, the lens illuminates red. If acoustic detection is enabled, any sound detected will illuminate the lens green.
4. As needed, adjust the angle of the sensor head to obtain optimal detection in the space.
5. Walk Test mode automatically exits and the sensor returns to normal operation after five minutes. You can also manually terminate by pressing the **[Walk Test]** button again.

Echoflex Installation Guide

Dual Tech Wall-mount Occupancy Sensor

Sensor Coverage

Narrow Lens

Top View

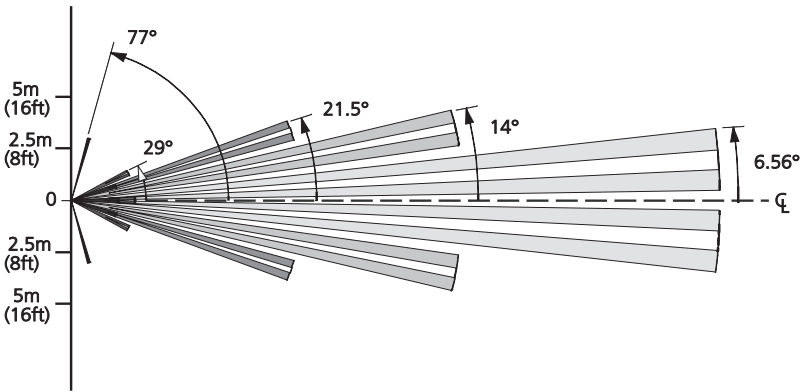

Side View

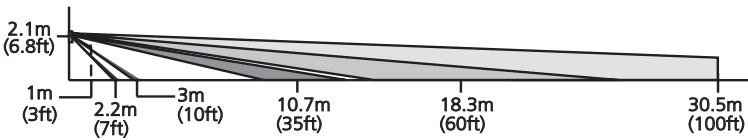

Echoflex Installation Guide

Dual Tech Wall-mount Occupancy Sensor

Wide Lens Top View

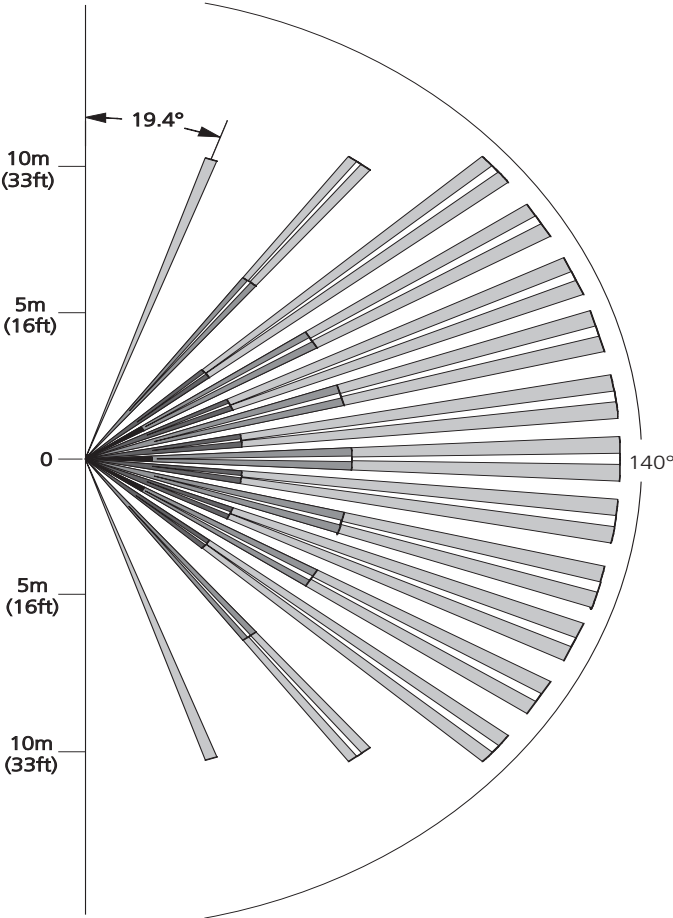

Side View

